

Steel Ball Valves

Floating Ball Design

PROVIDED BY: PT. SINAR MAS SAKTI
TEL: (62 21) 6008088 - FAX: (62 21) 6293410 - EMAIL: sales@smsakti.com



KITZ Steel Ball Valves

Floating Ball Design

Design and Inspection Standards of KITZ Flanged Ball Valves

Item	American Standards	British Standards
Pressure-temperature ratings	ASME B16.34	BS 5351
	KITZ Standard	
Shell wall thickness	ASME B16.34	BS 5351
Face-to-face dimensions	ASME B16.10	BS 2080 *1
End flange dimensions and flange gasket facing	ASME B16.5	BS 1560
Pressure test	API 598 or API 6D *2	BS 6755 Part 1 *2
Fire test	API 607 and API 6FA	BS 6755 Part 2

*1 Option for 2 to 4 Class 150 full port design.

*2 Option.

Product Coding for KITZ Flanged Ball Valves

Example:

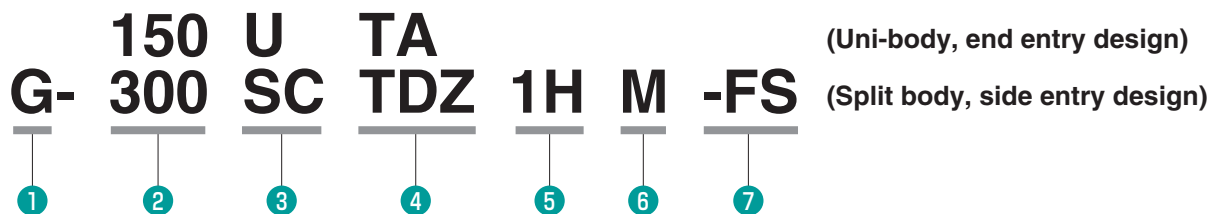

1 Valve operation measure

None Lever handle
 G Worm gear
 B KITZ Type B double action pneumatic actuator
 BS KITZ Type BS Spring return pneumatic actuator
 BSW KITZ Type BSW Spring return pneumatic actuator with manual operation device
 FA KITZ Type FA double action pneumatic actuator
 FAS KITZ Type FAS spring return pneumatic actuator
 HAS KITZ Type HAS Spring return pneumatic actuator
 E Electric actuator

2 ASME pressure class

150, 300, 600 or 1500

3 & 6 Shell material & Trim material

U: Symbol of stainless or high alloy steel
 SC: Symbol of carbon or low alloy steel

U/None CF8	U/CN CN7M
U/M CF8M	U/HB N-12MV
U/V CF3	U/HC CW-12MW
U/O CF3M	SC/None/None* ... WCB/CF8
U/CB CF8C	SC/None/M* WCB/CF8M
U/CG CG8M	SC/CL/None* LCC/CF8
U/CK CK20	SC/CL/M* LCC/CF8M
U/SD CD3MWCuN	

4 Valve design & type

TDZ Type TDZ
 TDZXL ... Extended bonnet, Type TDZ
 TB Type TB
 TR Type TR
 TBP Pocketless, Type TB
 TB2L 3-way 2-seat, L-port, Type TB
 TB2T 3-way 2-seat, T-port, Type TB
 TB4LA ... 3-way 4-seat, L-port, Type TB
 TB4TA ... 3-way 4-seat, T-port, Type TB
 TBT Direct routing to tank bottom
 TBJ Jacketed, Type TB
 TRJ Jacketed, Type TR
 TBLN PFA lined, Type TB
 TA Type TA

5 Seat Material

None HYPATITE® PTFE
 1H** FILLTITE®
 3H** Hard graphite seat for low abrasion service, 500°C
 5H** Metal seat for abrasive service, 300°C
 6H** Metal seat for high abrasive service, 500°C
 ** Type TDZ only

6 See 3

7 No symbol suffixed for PTFE packing and gasket.
 "FS" or "S" suffixed for flexible graphite packing and gasket for super-firesafe provision

This catalog uses **MPa**, a SI unit, for indication of pressures. **psi** and **kgf/cm²** are also added for readers convenience.

KITZ Steel Ball Valves

Floating Ball Design

The products introduced in this catalog are all covered by ISO 9001 and 9002 certification awarded KITZ Corporation, KITZ Corporation of Europe, S.A. and KITZ Corporation of Taiwan.



KITZ Corporation of Taiwan, Kaohsiung Plant, Taiwan (ISO 9002)



KITZ Corporation of Europe, S.A., Barcelona Plant, Spain (ISO 9001)



KITZ Corporation, Ina Plant, Japan (ISO 9001)



KITZ Corporation, Nagasaka Plant, Japan (ISO 9001)

Contents

Design and Inspection Standards	1
KITZ Product Coding	1
Product Range	2
Pressure-Temperature Ratings	6
Design Features	12
KITZ HYPATITE® PTFE Ball Seats	15
KITZ Ball Seat Materials	16
Class 150/300 Carbon Steel (Split body) Ball Valves	17
Class 150/300 Carbon Steel (Uni-body) Ball Valves	18
Class 600/1500 Carbon Steel (Split body) Ball Valves	19
Class 150/300 Stainless Steel (Split body) Ball Valves	20
Class 150 Stainless Steel (Split body) Ball Valves	21
Class 150/300 Stainless Steel (Uni-body) Ball Valves	22
Class 600/1500 Stainless Steel (Split body) Ball Valves	23
Class 150 Low Temperature Service Ball Valves	24
Class 300 Low Temperature Service Ball Valves	25
Class 150 Stainless Steel 3-way Ball Valves	26
Class 150 Stainless Steel Pocketless Ball Valves	27
Class 150 Stainless Steel Jacketed Ball Valves	27
Class 150 Stainless Steel Tank Ball Valves	28
JIS 10K Stainless Steel PFA Lined Ball Valves	28
Type 600 Carbon Steel Ball Valves (Threaded)	29
Type 1500/2000 Carbon Steel Ball Valves (Threaded)	29
Type 1500/2000 Welded Body Carbon Steel Ball Valves (Threaded)	30
Class 800 Welded Body Carbon Steel Ball Valves (Threaded)	30
Type 3000 Welded Body Carbon Steel Ball Valves (Threaded)	30
Class 800 Carbon Steel Ball Valves (Welding)	31
Type 3000 Carbon Steel Ball Valves (Welding)	31
Type 1000 3-piece Carbon Steel Ball Valves (Threaded or Welding)	31
Type 1000 3-piece Carbon Steel Ball Valves (Threaded or Welding)	32
Type 600 Stainless Steel Ball Valves (Threaded)	32
Type 800 Stainless Steel Ball Valves (Threaded)	33
Type 1500 Stainless Steel Ball Valves (Threaded)	33
Type 1500/2000 Stainless Steel Ball Valves (Threaded)	34
Type 1500/2000 Welded Body Stainless Steel Ball Valves (Threaded)	34
Type 1000 3-piece Stainless Steel Ball Valves (Threaded or Welding)	35
Type 1000 3-piece Stainless Steel Ball Valves (Threaded or Welding)	35
Type 800 Stainless Steel 3-way Ball Valves (Threaded)	36
Class 150 Stainless Steel Ball Valves (Threaded)	36
Dimensions of Actuator Mounting Pads	37
Construction and Materials	40

■ Technical Information

Technical Features of KITZ HYPATITE® PTFE and SWELLESS® Ball Seats	50
General Precautions	52
Flow Characteristics	53
Steel Pipe Flanges	54

Product Range

Flanged Floating Ball Valves

Shell Material	Class	KITZ Product Code	Bore *1	Body Design	Size		in.																	Page
					mm	15	20	25	32	40	50	65	80	100	125	150	200	250	300					
Carbon Steel	150	150SCTDZ	F	Split		●	●	●		●	●	●	●	●	●	●	●	■*2		17				
	150	150SCTA	R	Uni		●	●	●		●	●		●	●		●	●	●		18				
	300	300SCTDZ	F	Split		●	●	●		●	●	●	●	●	●	●	●	●		17				
	300	300SCTA	R	Uni		●	●	●		●	●		●	●		●	●	●		18				
	600	600SCTB	F	Split		●	●	●		●										19				
	1500	1500SCTB	F	Split		●	●	●		●										19				
	150	150SCTR	R	Split											●	●	●	●	■	*3				
	300	300SCTR	R	Split											●	●	●	●		*3				
	JIS 10K	10SCTDZ	F	Split		●	●	●		●	●	●	●	●	●	●	●	●	■		*3			
	JIS 20K	20SCTDZ	F	Split		●	●	●		●	●	●	●	●	●	●	●	●	●		*3			
Stainless Steel	150	150UTDZM	F	Split		●	●	●	●	●	●	●	●	●	●	●	●	■		20				
	150	150UTBM	F	Split		●	●	●		●	●	●	●	●	●	●	●	■		21				
	150	150UTAM	R	Uni		●	●	●		●	●		●	●		●	●	●		22				
	300	300UTDZM	F	Split		●	●	●	●	●	●	●	●	●	●	●	●	●		20				
	300	300UTAM	R	Uni		●	●	●		●	●		●	●		●	●	●		22				
	600	600UTBM	F	Split		●	●	●		●										23				
	1500	1500UTBM	F	Split		●	●	●		●										23				
	150	150UTDZXL	F	Split/Extended bonnet		●	●	●	●	●	●	●	●	●	■	■	■	■			24			
	300	300UTDZXL	F	Split/Extended bonnet		●	●	●	●	●	●	●	●	■	■	■	■				25			
	150	150UTRM	R	Split						●	●	●	●	●	●	●	●	●	■		*3			
	300	300UTRM	R	Split						●		●	●		●	●	●			*3				
	JIS 10K	10UTDZM	F	Split		●	●	●	●	●	●	●	●	●	●	●	●	■		*3				
	JIS 20K	20UTDZM	F	Split		●	●	●	●	●	●	●	●	●	●	●	●			*3				
	150	150UTB2LM/2TM	F	Split/3-way·2-seat				●		●	●	●	●	●		●	●	●*6		26				
	150	150UTB4LAM/4TAM	F	Split/3-way·4-seat		●	●	●		●	●	●	●	●	●	●*6	●*6	●*6		26				
	JIS 10K	10UTB2LM/2TM	F	Split/3-way·2-seat				●		●	●	●	●	●		●	●	●*6		*3				
	JIS 10K	10UTB4LAM/4TAM	F	Split/3-way·4-seat		●	●	●		●	●	●	●	●	●	●*6	●*6	●*6		*3				
	150	150UTBPM	F	Split/Pocketless		●	●	●		●	●	●	●	●	●	●	●	●		27				
	150	150UTBJM	F	Jacketed		●	●	●		●	●	●								27				
	JIS 10K	10UTBJM	F	Jacketed		●	●	●		●	●	●								*3				
	150	150UTRJM	R	Jacketed									●	●		●				*3				
	JIS 10K	10UTRJM	R	Jacketed									●	●		●				*3				
	150	150UTBTM	F	Split/Tank ball				●		●	●	●	●	●	●	●	●	■		28				
	JIS 10K	10UTBTM	F	Split/Tank ball				●		●	●	●	●	●	●	●	●	■		*3				
150	150UTBLN	F	Split/PFA lined		●	●	●		●	●	●	●							*3					
JIS 10K	10UTBLN	F	Split/PFA lined		●	●	●		●	●	●	●							28					
Ductile Iron	JIS 10K	10STBF	F	Split		●	●	●	●	●	●	●	●	●	●	●	●		*4					
	JIS 10K	10STLBF	F	Split/Gas service		●	●	●	●	●	●	●	●	●	●	●	●		*4					
	JIS 20K	20STLB	F	Split/Gas service		●	●	●	●	●	●	●	●		●	●			*4					
	JIS 10K	10STB4LAF/4TAF	F	Split/3-way·4-seat					●	●	●	●	●						*4					
	JIS 10K	10STR4LAF/4TAF	R	Split/3-way·4-seat										●	●	●			*4					
Cast Iron	125	125FCTB	F	Split						●	●	●	●		●	●			*5					
	JIS 10K	10FCTB	F	Split		●	●	●	●	●	●	●	●	●	●	●	■		*5					
	JIS 10K	10FCTB2L	F	Split/3-way·2-seat					●	●	●	●	●						*5					
	JIS 10K	10FCTR2L	R	Split/3-way·2-seat										●	●	●			*5					

*1 Bore design: F=Full port, R=Reduced port
 *2 Worm gear operation is standardised for the sizes marked ■ with the prefix "G-" on each KITZ product code.
 *3 Please contact KITZ Corporation for details.
 *4 Refer to KITZ Ductile Iron Valves catalog (No. E-140) for details.
 *5 Refer to KITZ Cast Iron Valves catalog (No. E-120) for details.
 *6 Reduced port.

Product Range

Flanged High Performance Ball Valves

Shell Material	Class	KITZ Product Code	Bore*1	Body Design	Size																Page
					in.	1/2	3/4	1	1 1/4	1 1/2	2	2 1/2	3	4	5	6	8	10	12	14	
					mm	15	20	25	32	40	50	65	80	100	125	150	200	250	300	350	
Λ - port Stainless Steel	150	L-150UVC (T) M*2	F	Split/For control				●		●	●	●	●	●	●	●	●				*4
	150	G-150UVC (T) M*2	F	Split/For control												●	●	●	●		*4
	300	L-300UVC (T) M*2	F	Split/For control				●		●	●	●	●	●	●	●	●				*4
	300	G-300UVC (T) M*2	F	Split/For control												●	●	●			*4
	JIS 10K	L-10UVC (T) M*2	F	Split/For control				●		●	●	●	●	●	●	●	●				*4
	JIS 10K	G-10UVC (T) M*2	F	Split/For control												●	●	●	●		*4
	JIS 20K	L-20UVC (T) M*2	F	Split/For control				●		●	●	●	●	●	●	●	●				*4
	JIS 20K	G-20UVC (T) M*2	F	Split/For control												●	●	●			*4
FILL TITE® Seated Carbon Steel and Stainless Steel	150	150SCTDZ1H	F	Split/Max. 300°C	●	●	●		●	●	●	●	●	●	■	■	■	■			*5
	150	150UTDZ1HM	F	Split/Max. 300°C	●	●	●	●	●	●	●	●	●	●	■	■	■	■			*5
	300	300SCTDZ1H	F	Split/Max. 300°C	●	●	●		●	●	●	●	●	●	■	■	■	■			*5
	300	300UTDZ1HM	F	Split/Max. 300°C	●	●	●	●	●	●	●	●	●	●	■	■	■	■			*5
	JIS 10K	10SCTDZ1H	F	Split/Max. 300°C	●	●	●		●	●	●	●	●	●	■	■	■	■			*5
	JIS 10K	10UTDZ1HM	F	Split/Max. 300°C	●	●	●	●	●	●	●	●	●	●	■	■	■	■			*5
	JIS 20K	20SCTDZ1H	F	Split/Max. 300°C	●	●	●		●	●	●	●	●	●	■	■	■	■			*5
	JIS 20K	20UTDZ1HM	F	Split/Max. 300°C	●	●	●	●	●	●	●	●	●	●	■	■	■	■			*5
Graphite Seated Carbon and Stainless Steel	150	150SCTDZ3H	F	Split/Max. 500°C	●	●	●		●	●	●	●	●	●	■	■	■	■			*5
	150	150UTDZ3HM	F	Split/Max. 500°C	●	●	●	●	●	●	●	●	●	●	■	■	■	■			*5
	300	300SCTDZ3H	F	Split/Max. 500°C	●	●	●		●	●	●	●	●	●	■	■	■	■			*5
	300	300UTDZ3HM	F	Split/Max. 500°C	●	●	●	●	●	●	●	●	●	●	■	■	■	■			*5
	JIS 10K	10SCTDZ3HM	F	Split/Max. 300°C	●	●	●		●	●	●	●	●	●	■	■	■	■			*5
	JIS 10K	10UTDZ3HM	F	Split/Max. 300°C	●	●	●	●	●	●	●	●	●	●	■	■	■	■			*5
	JIS 20K	20SCTDZ3H	F	Split/Max. 425°C	●	●	●		●	●	●	●	●	●	■	■	■	■			*5
	JIS 20K	20UTDZ3HM	F	Split/Max. 425°C	●	●	●	●	●	●	●	●	●	●	■	■	■	■			*5
Metal Seated Carbon and Stainless Steel	150	150SCTDZ5H	F	Split/Max. 300°C	●	●	●		●	●	●	●	●	●	■	■	■	■			*5
	150	150UTDZ5HM	F	Split/Max. 300°C	●	●	●	●	●	●	●	●	●	●	■	■	■	■			*5
	300	300SCTDZ5H	F	Split/Max. 300°C	●	●	●		●	●	●	●	●	●	■	■	■	■			*5
	300	300UTDZ5HM	F	Split/Max. 300°C	●	●	●	●	●	●	●	●	●	●	■	■	■	■			*5
	JIS 10K	10SCTDZ5H	F	Split/Max. 300°C	●	●	●		●	●	●	●	●	●	■	■	■	■			*5
	JIS 10K	10UTDZ5HM	F	Split/Max. 300°C	●	●	●	●	●	●	●	●	●	●	■	■	■	■			*5
	JIS 20K	20SCTDZ5H	F	Split/Max. 300°C	●	●	●		●	●	●	●	●	●	■	■	■	■			*5
	JIS 20K	20UTDZ5HM	F	Split/Max. 300°C	●	●	●	●	●	●	●	●	●	●	■	■	■	■			*5
Metal Seated Carbon and Stainless Steel	150	150SCTDZ6H	F	Split/Max. 500°C	●	●	●		●	●	●	●	●	●	■	■	■	■			*5
	150	150UTDZ6HM	F	Split/Max. 500°C	●	●	●	●	●	●	●	●	●	●	■	■	■	■			*5
	300	300SCTDZ6H	F	Split/Max. 500°C	●	●	●		●	●	●	●	●	●	■	■	■	■			*5
	300	300UTDZ6HM	F	Split/Max. 500°C	●	●	●	●	●	●	●	●	●	●	■	■	■	■			*5
	600	600SCTB6H	F	Split/Max. 500°C	●	●	●		●												*5
	600	600UTB6HM	F	Split/Max. 500°C	●	●	●		●												*5
	JIS 10K	10SCTDZ6H	F	Split/Max. 300°C	●	●	●		●	●	●	●	●	●	■	■	■	■			*5
	JIS 10K	10UTDZ6HM	F	Split/Max. 300°C	●	●	●	●	●	●	●	●	●	●	■	■	■	■			*5
	JIS 20K	20SCTDZ6H	F	Split/Max. 425°C	●	●	●		●	●	●	●	●	●	■	■	■	■			*5
	JIS 20K	20UTDZ6HM	F	Split/Max. 425°C	●	●	●	●	●	●	●	●	●	●	■	■	■	■			*5

*1 Bore design: F=Full port
 *2 Operation: L=Lever, G=Gear
 *3 Worm gear operation is standardised for the sizes marked ■ with the prefix "G-" on each KITZ product code.
 *4 Refer to KITZ Λ -port Quarter-Turn Control Valves catalog (No. E-203) for details.
 *5 Refer to KITZ Steel Ball Valve for High Temperature (No. E-204) for details.
 *6 Please contact KITZ Corporation for details.

PROVIDED BY: PT. SINAR MAS SAKTI
 TEL: (62 21) 6008088 - FAX: (62 21) 6293410 - EMAIL: sales@smsakti.com

Product Range

Flanged High Performance Ball Valves

Shell Material	Class	KITZ Product Code	Bore *1	Body Design	Size																Page	
					in.	1/2	3/4	1	1 1/4	1 1/2	2	2 1/2	3	4	5	6	8	10	12	14		
					mm	15	20	25	32	40	50	65	80	100	125	150	200	250	300	350		
Titanium	150	150TTB	F	Split		●	●	●		●	●	●	●	●	●	●	●					*
	300	300TTB	F	Split		●	●	●		●	●	●	●	●		●	●					*
	JIS 10K	10TTB	F	Split		●	●	●		●	●	●	●	●	●	●	●					*
	JIS 20K	20TTB	F	Split		●	●	●		●	●	●	●	●	●		●	●				*

* Please contact KITZ Corporation for details.

Flanged Trunnion Mounted Ball Valves

Shell Material	Class	KITZ Product Code	Bore *1	Body Design	Size																Page						
					in.	2	3	4	6	8	10	12	14	16	18	20	22	24	26	28		30	32	34	36		
					mm	50	80	100	150	200	250	300	350	400	450	500	550	600	650	700	750	800	850	900			
Carbon Steel	150	150SCTCS	F	Super-firesafe *3	●	●	●	●	●	■	■	■	■	■	■	■	■	■	■	■	■	■	■	■	■	*2	*4
	300	300SCTCS	F	Super-firesafe *3	●	●	●	●	●	■	■	■	■	■	■	■	■	■	■	■	■	■	■	■	■	■	*4
	600	600SCTCS	F	Super-firesafe *3	●	●	●	●	■	■	■	■	■	■	■	■	■	■	■	■	■	■	■	■	■	■	*4
	900	900SCTCS	F	Super-firesafe *3	●	●	●	■	■	■	■	■	■	■	■	■	■	■	■	■	■	■	■	■	■	■	*4
	1500	1500SCTCS	F	Super-firesafe *3	●	●	■	■	■	■	■	■	■	■	■	■	■	■	■	■	■	■	■	■	■	■	*4
Stainless Steel	150	150UTCSCM	F	Super-firesafe *3	●	●	●	●	●	■	■	■	■	■	■	■	■	■	■	■	■	■	■	■	■	*4	
	300	300UTCSCM	F	Super-firesafe *3	●	●	●	●	●	■	■	■	■	■	■	■	■	■	■	■	■	■	■	■	■	*4	
	600	600UTCSCM	F	Super-firesafe *3	●	●	●	●	■	■	■	■	■	■	■	■	■	■	■	■	■	■	■	■	■	*4	
	900	900UTCSCM	F	Super-firesafe *3	●	●	●	■	■	■	■	■	■	■	■	■	■	■	■	■	■	■	■	■	■	■	*4
	1500	1500UTCSCM	F	Super-firesafe *3	●	●	■	■	■	■	■	■	■	■	■	■	■	■	■	■	■	■	■	■	■	■	*4

*1 Bore design: F=Full port (Reduced port type is also available.)
 *2 Worm gear operation is standard for the sizes marked ■ with the prefix "G-" on each KITZ product code.
 *3 Non firesafe types are also available.
 *4 Refer to KITZ Trunnion Mounted Ball Valves catalog (No. E-202) for details.

PROVIDED BY: PT. SINAR MAS SAKTI
 TEL: (62 21) 6008088 - FAX: (62 21) 6293410 - EMAIL: sales@smsakti.com

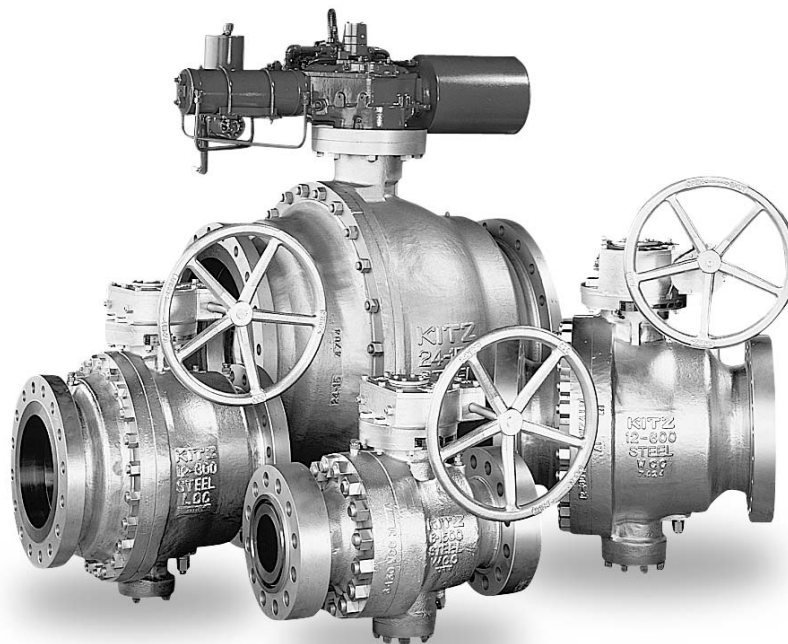

● Trunnion Mounted Ball Valves

Product Range

Threaded or Welded Ball Valves

Shell Material	Class	KITZ Product Code	Bore *1	Body Design	Size		1/4	3/8	1/2	3/4	1	1 1/4	1 1/2	2	2 1/2	3	Page
					in.	mm	8	10	15	20	25	32	40	50	65	80	
Carbon Steel	600WOG	SCTK *2	D	Uni/Threaded ends	●	●	●	●	●	●	●	●	●				29
	800	800SCTK *3	R	Seal welded/Threaded or Socket welded ends	●	●	●	●	●	●	●	●	●	●			30,31
	1000WOG	SC3TZF *3	F	3-piece/Threaded or Socket welded ends	●	●	●	●	●	●	●	●					31
	1000WOG	SC3TZ *3	R	3-piece/Threaded Socket or welded ends			●	●	●	●	●	●	●				32
	1500/2000 WOG	AKSCTHZM *4	R	Split/Threaded ends	●	●	●	●	●	●	●	●	●				29
	1500/2000 WOG	AKSCTHWZM *4	R	Seal welded/Threaded ends	●	●	●	●	●	●	●	●	●				30
	3000WOG	3000SCTK *3	R	Seal welded/Threaded or Socket welded ends	●	●	●	●	●	●	●	●	●	●			30,31
Stainless Steel	600WOG	UTKM *2	D	Uni/Threaded ends	●	●	●	●	●	●	●	●	●				32
	800WOG	UTHM *2	R	Split/Threaded ends			●	●	●	●	●	●	●				33
	1500WOG	UTFM *2	F	Split/Threaded ends			●	●	●	●	●	●	●				33
	800WOG	UTH4LM/4TM	R	Split/3-way-4-seat/Threaded ends			●	●	●	●	●	●	●				36
	1000WOG	U3TZFM *3	F	3-piece/Threaded or Socket or welded ends	●	●	●	●	●	●	●	●					35
	1000WOG	U3TZM *3	R	3-piece/Threaded or Socket or welded ends			●	●	●	●	●	●	●				35
	1500/2000 WOG	AKUTHZM *4	R	Split/Threaded ends	●	●	●	●	●	●	●	●	●				34
	1500/2000 WOG	AKUTHWZM *4	R	Seal welded/Threaded ends	●	●	●	●	●	●	●	●	●				34
	150	AK150UTM *4	F	Split/Threaded ends		●	●	●	●	●	●	●	●	●	●	●	36
	JIS 10K	10UTM	F	Split/Threaded ends		●	●	●	●	●	●	●	●	●	●	●	*5
Cast Ductile Iron	JIS 20K	20ST	R	Split/Threaded ends			●	●	●	●	●	●	●				*6
	400WOG	STZ	R	Split/Threaded ends	●	●	●	●	●	●	●	●	●				*6
	JIS 10K	10FCT	R	Split/Threaded ends		●	●	●	●	●	●	●	●	●	●		*7

*1 Bore design: F=Full port, R=Regular port, D=Reduced port

*2 Rc threaded ends are standard. Prefix "AK" means NPT threaded end.

*3 Rc threaded ends are standard. Prefix "AK" means NPT threaded ends and "AW" means socket welded ends.

*4 NPT threaded ends are only available.

*5 Please contact KITZ Corporation for details.

*6 Refer to KITZ Ductile Iron Valves catalog (No. E-140) for details.

*7 Refer to KITZ Cast Iron Valves catalog (No. E-120) for details.



● 1-port Ball Valves

PROVIDED BY: PT. SINAR MAS SAKTI
 TEL: (62 21) 6008088 - FAX: (62 21) 6293410 - EMAIL: sales@smsakti.com

Pressure-Temperature Ratings

The pressure-temperature ratings of ball valves are determined, not only by valve shell materials, but more essentially by sealing materials, used for ball seats, gland packing and gaskets. Sealing materials may be high molecule, or rubber, but the choice is limited by the characteristics of the service fluid, working temperatures, working pressures, velocity of fluid, and operational frequency of valves.

As it is very difficult to predetermine the exact pressure-temperature rating for all kinds of fluid under all imaginable conditions, we have prepared general rating charts for non-

shock fluid service here, based on our past experiences both in the field and in our laboratory.

In case of extraordinary service conditions as mentioned below, contact KITZ Corporation or its distributors for technical advice:

1. Valves shall be left fully closed for a long period of time under high temperature or high differential pressure.
2. Valves shall be frequently operated under high temperature or high differential pressure.
3. Frequent change of line pressure or temperature.

HYPATITE® PTFE is the standard seat material for KITZ ball valves. Specify virgin PTFE or carbon-filled PTFE when required. The body ratings shown here are for ASTM A216 Gr. WCB and A351 Gr. CF8M. For the pressure ratings of other valve shell materials, refer to the latest edition of ASME B16.34.

FILLTITE® is a specially reinforced ball seat, made by using carbon based fillers into PTFE at higher rate than conventional carbon filled PTFE, which greatly improves heat and abrasion resistance. The material shows excellent operability, durability, chemical resistance and sealing performance at a high temperature of 300°C. In addition, the ball seat is replaceable with the most of our conventional ball seats, so it also has the cost advantage.

Pressure-Temperature Ratings

150/300 UTDZM/SCTDZ: 1/2", 3/4"

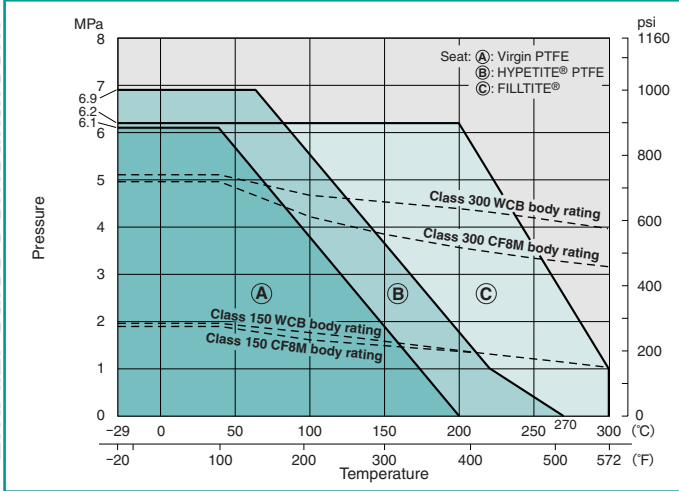

150/300 UTDZM/SCTDZ: 1"~2 1/2"

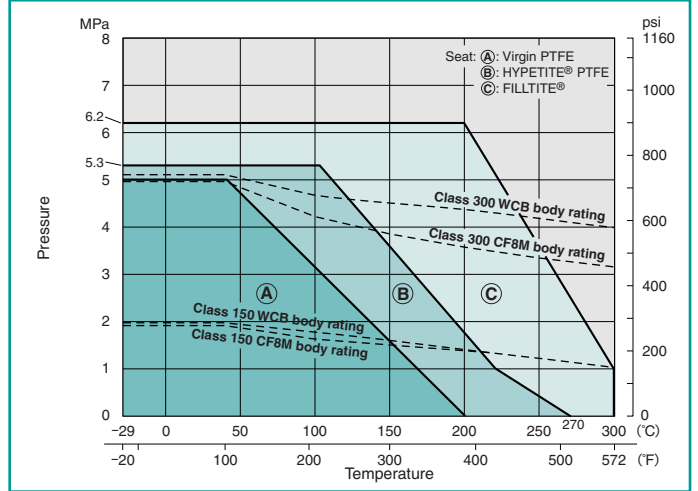

150/300 UTDZM/SCTDZ: 3", 4"

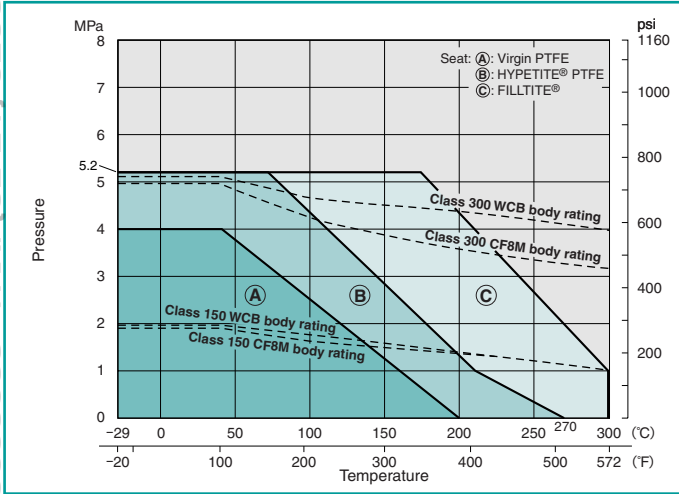

150/300 UTDZM/SCTDZ: 5", 6"

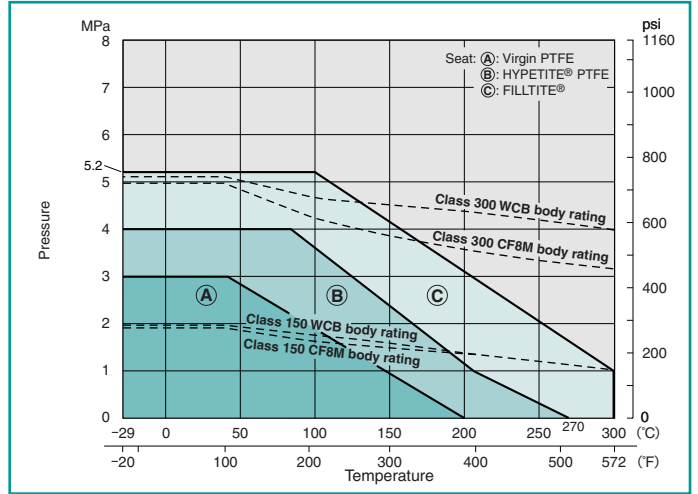

150/300 UTDZM/SCTDZ: 8", 10"

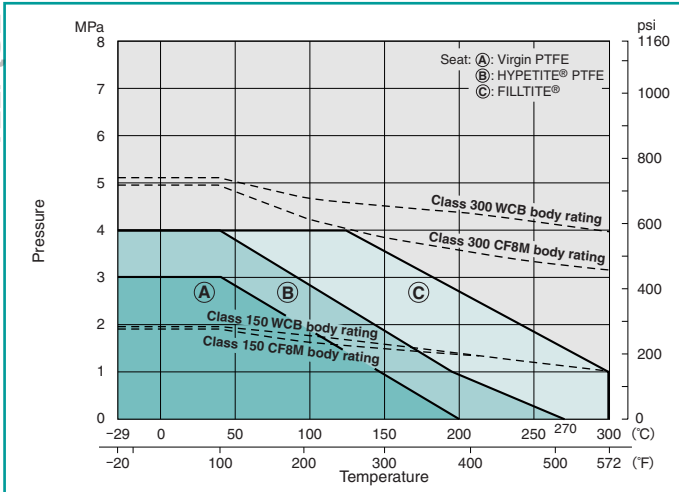

PROVIDED BY: PT. SINAR MAS SAKTI
 TEL: (62 21) 6008088 - FAX: (62 21) 6293410 - EMAIL: sales@smsakti.com

Pressure-Temperature Ratings

150 UTBM : 1/2" & 3/4"*
150/300 SCTA/UTAM : 1/2" to 1"

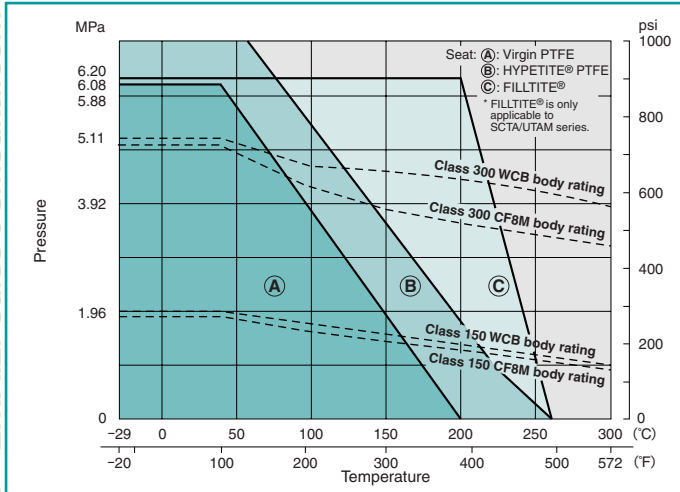

150 UTBM : 1" to 2 1/2"*
150/300 SCTA/UTAM : 1 1/2" to 3"

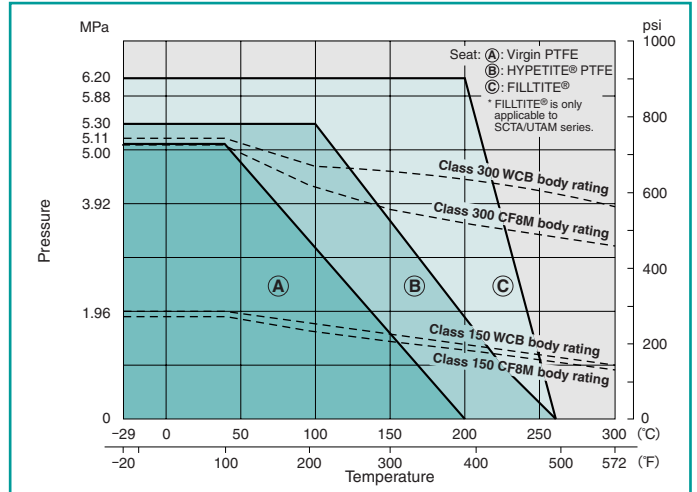

150 UTBM : 3" & 4"*
150/300 SCTA/UTAM : 4" & 6"

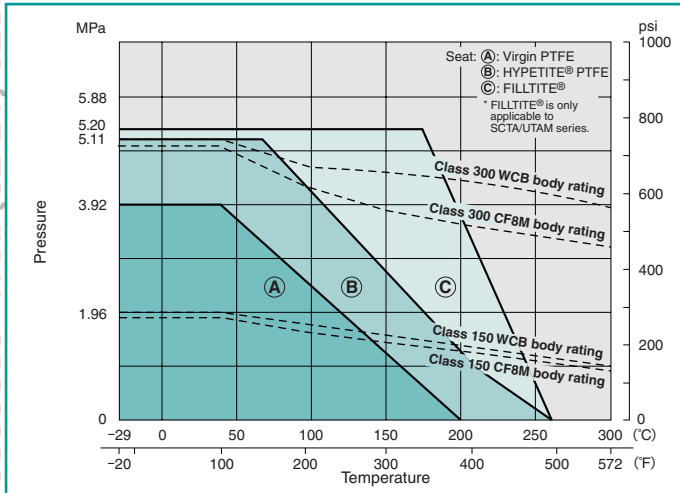

150 UTBM : 5" & 6"*
150/300 SCTA/UTAM : 8" & 10"

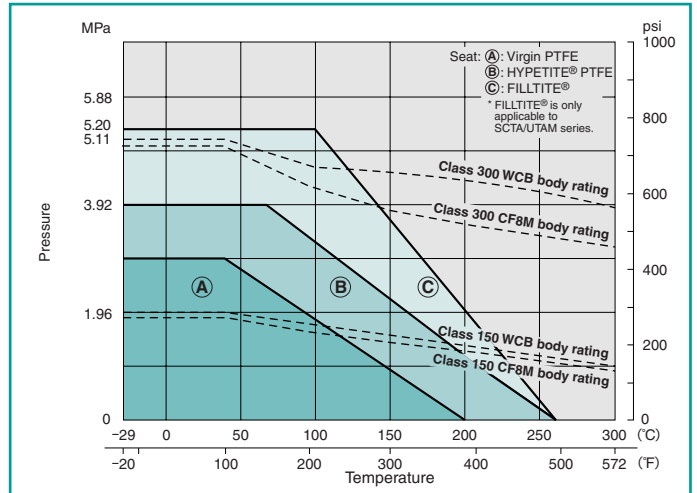

150 UTBM : 8" & 10"

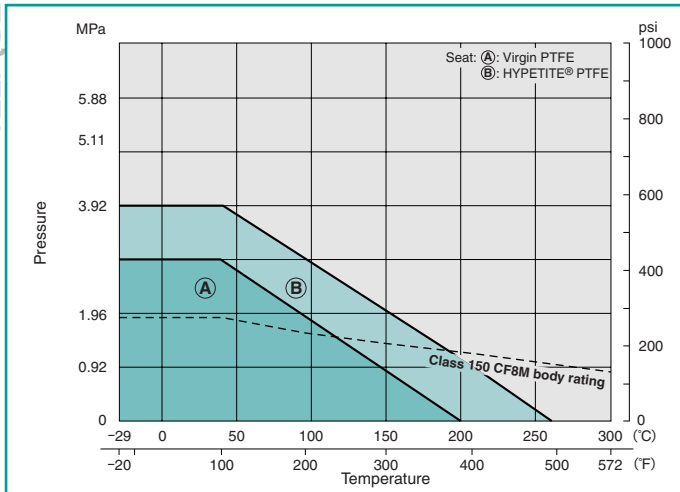

PROVIDED BY: PT. SINAR MAS SAKTI
 TEL: (62 21) 6008088 - FAX: (62 21) 6293410 - EMAIL: sales@smsakti.com

Pressure-Temperature Ratings

600/1500 SCTB/UTBM

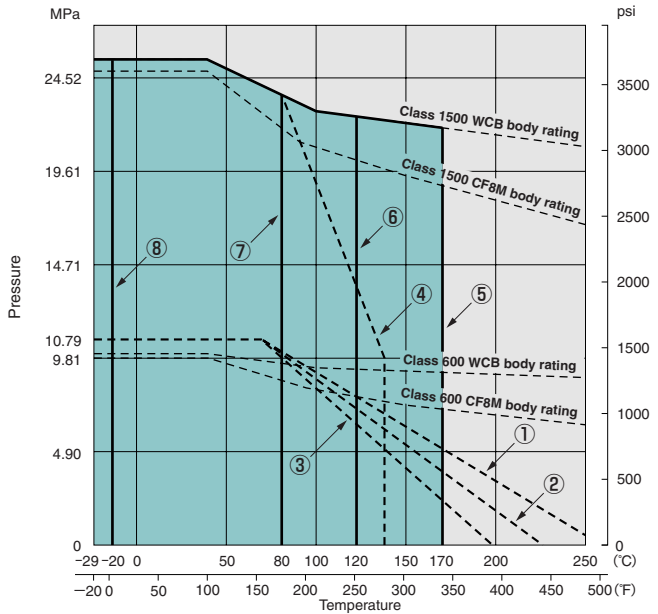

Ball Seat Materials

- ①: KITZ HYPATITE® or Carbon-filled PTFE
- ②: Glass-filled PTFE with MoS₂
- ③: Virgin PTFE
- ④: Nylon with MoS₂

O-ring Upper Limit

- ⑤: (1) FKM
(2) Low-temperature FKM
- ⑥: (1) EPDM
(2) ECO (Epichlorohydrin Copolymer)
- ⑦: (1) NBR
(2) Low-temperature NBR

O-ring Lower Limit

- ⑧: FKM
- * O-rings made of others than FKM can withstand -29°C (-20°F)

150/300 UTDZXL

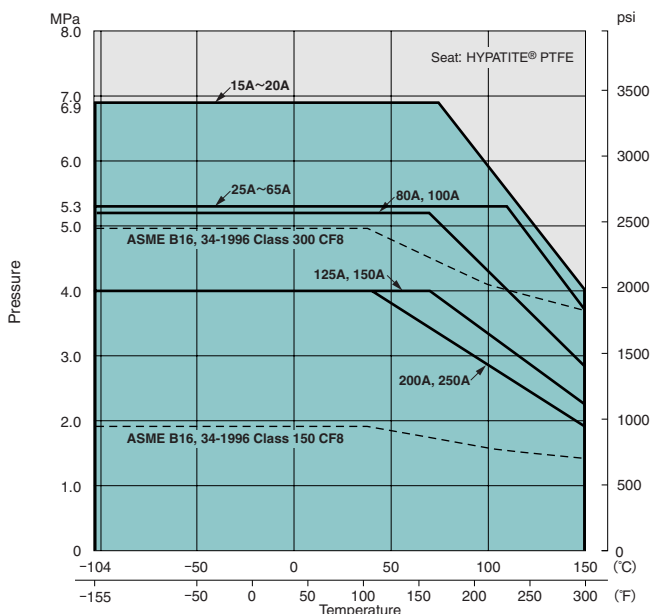

3-way: 150UTB4LAM/4TAM

* Refer to 150UTBM ratings for 150UTB2LM/2TM

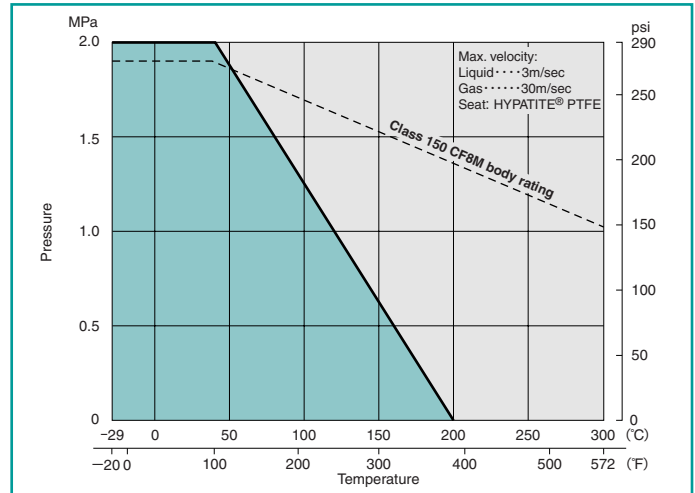

PFA Lined: 10UTBLN

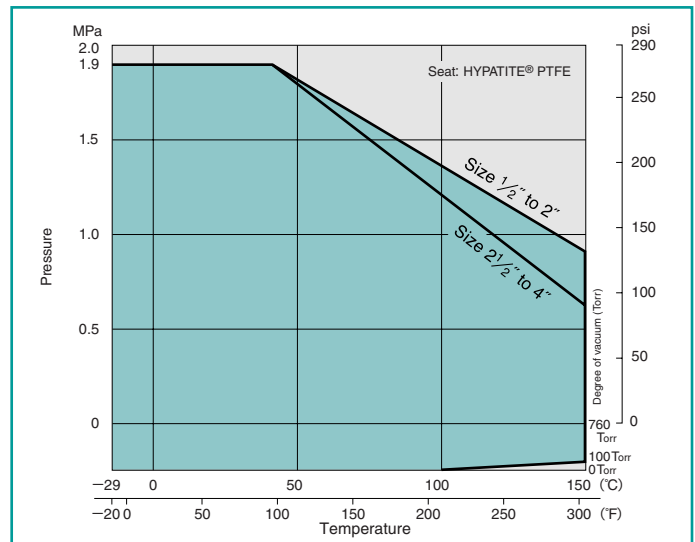

PROVIDED BY: PT. SINAR MAS SAKTI
TEL: (62 21) 6008088 - FAX: (62 21) 6293410 - EMAIL: sales@smsakti.com

Pressure-Temperature Ratings

Type 600 : SCKT/UTKM

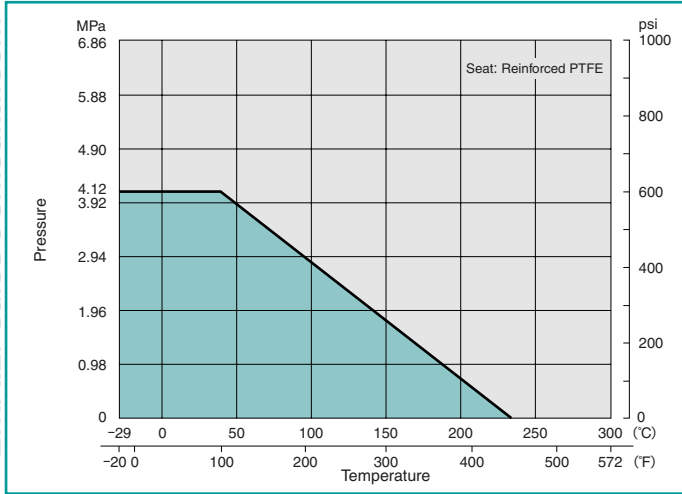

Type 1000 : UTFM

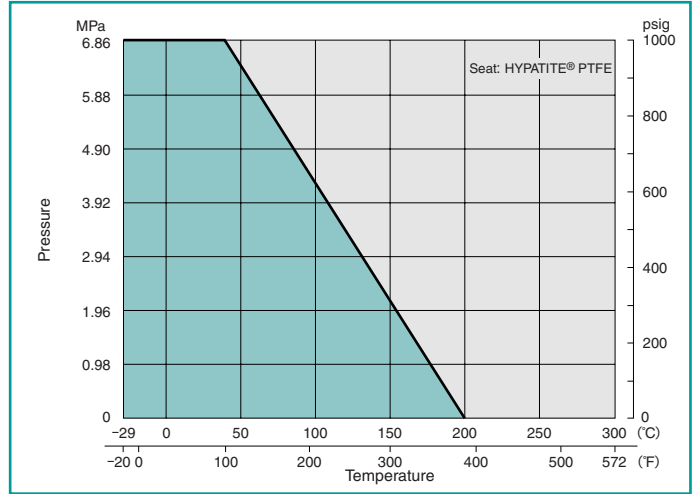

Type 800 : UTHM

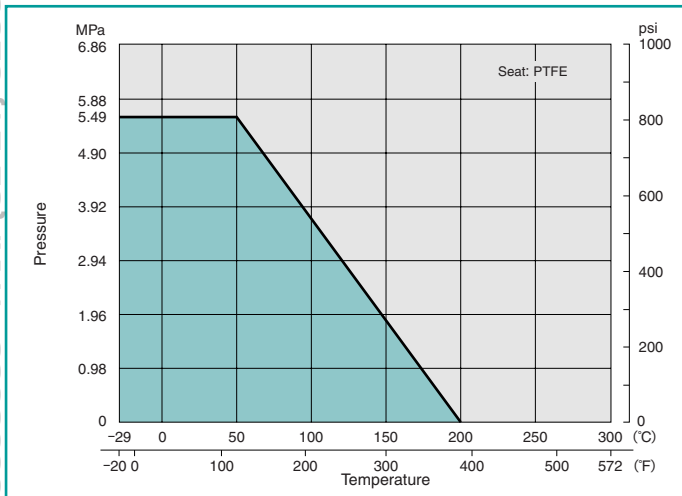

Class 800 and Type 3000 : SCKT

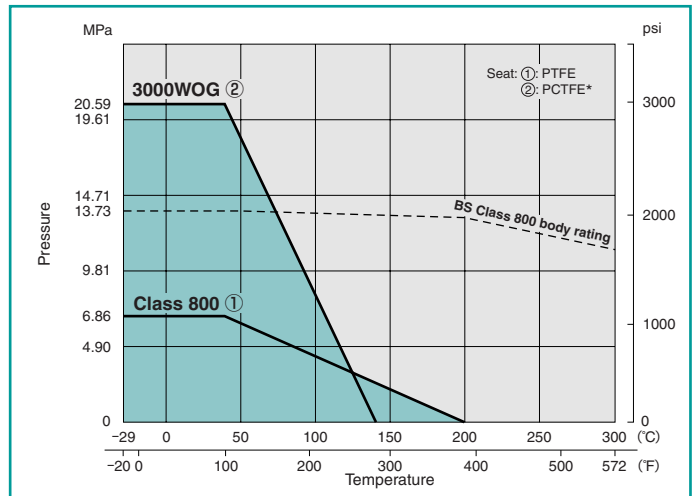

* Polychloro-Trifluoro-Ethylene

Type 800 : UTH4LM/4TM

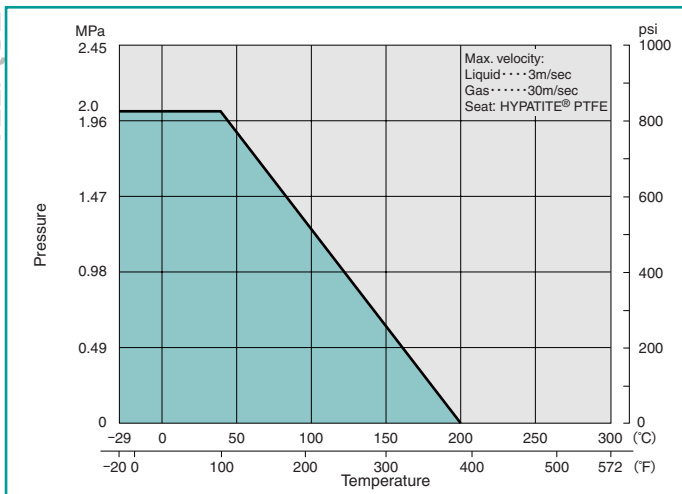

Type 1000 : SC3TZ/U3TZ Series

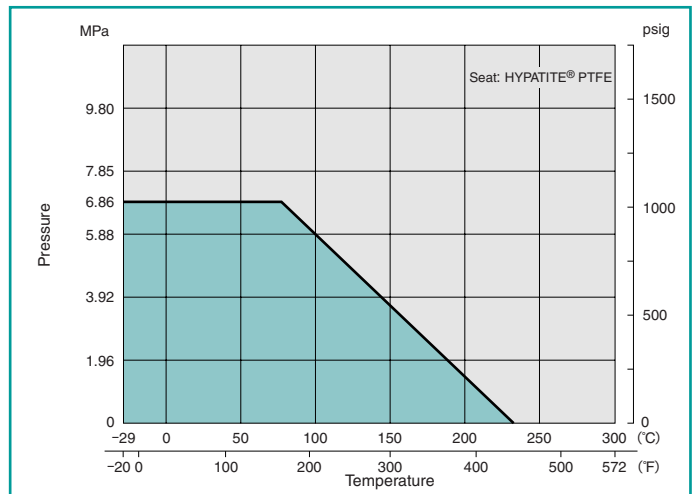

Note: Type 1500 is optionally available

PROVIDED BY: PT. SINAR MAS SAKTI
 TEL: (62 21) 6008088 - FAX: (62 21) 6293410 - EMAIL: sales@smsakti.com

Pressure-Temperature Ratings

Type 1500/2000:
AKSCTHZM/AKSCTHWZM/AKUTHZM/AKUTHWZM

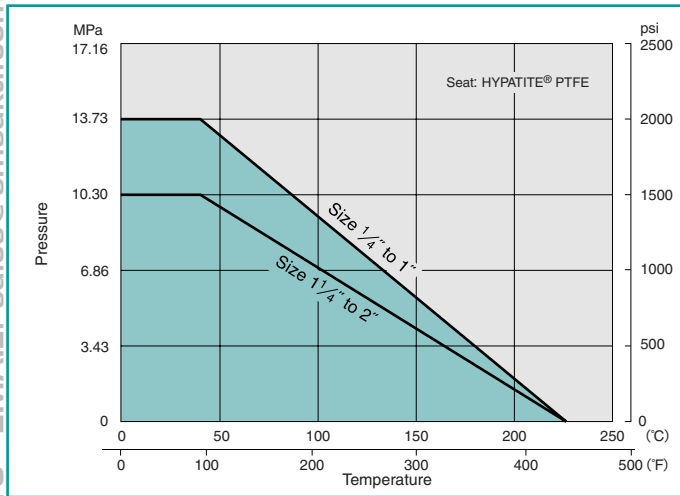

Class 150: AK150UTM

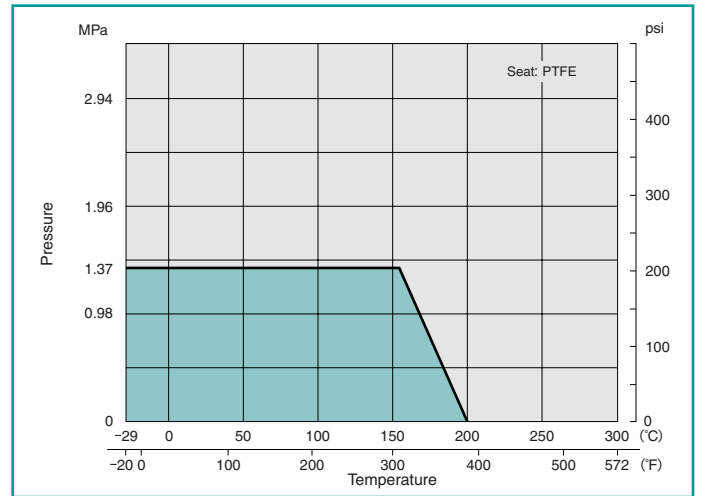

PROVIDED BY: PT. SINAR MAS SAKTI
 TEL: (62 21) 6008088 - FAX: (62 21) 6293410 - EMAIL: sales@smsakti.com

KITZ 150/300 SCTDZ/UTDZM Series Full Port, Split Body, Side Entry Ball Valves

This is an illustrated cross-section of a typical KITZ split body floating type full port ball valve to exhibit the basic design concept. The actual design of a valve may be slightly different from this illustration, depending on its size and pressure class.

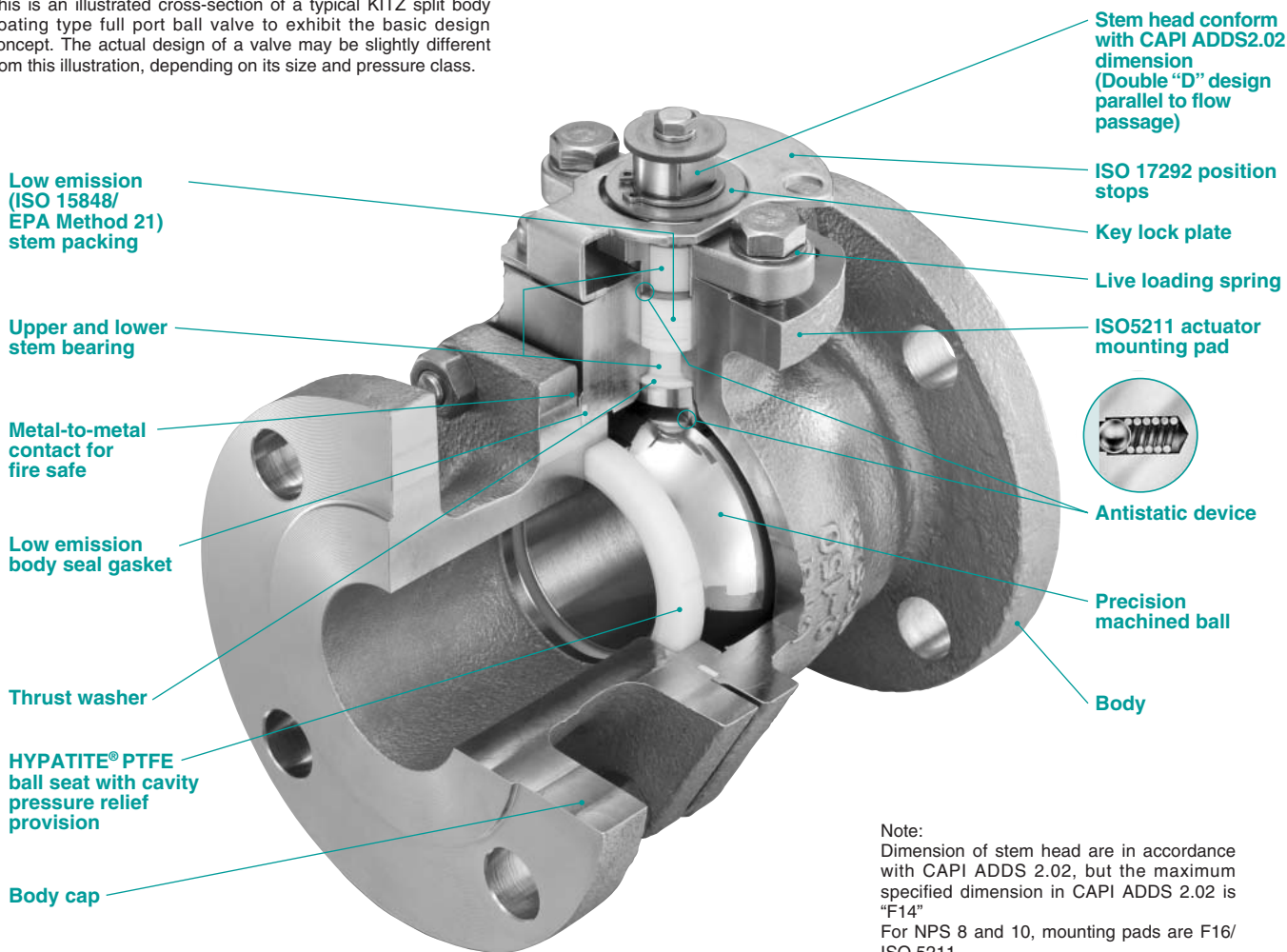

2" KITZ 150UTDZ

Note:
Dimension of stem head are in accordance with CAPI ADDS 2.02, but the maximum specified dimension in CAPI ADDS 2.02 is "F14"
For NPS 8 and 10, mounting pads are F16/ ISO 5211.

PROVIDED BY: PT. SINAR MAS SAKTI
TEL: (62 21) 6008088 - FAX: (62 21) 6293410 - EMAIL: sales@smsakti.com

Bubble-tight sealing performance with HYPATITE® PTFE ball seats

HYPATITE® PTFE ball seats, standard stem seals of KITZ ball valves, are made of denatured PTFE, a molecularly reinforced PTFE copolymer, and specifically engineered for high **bi-directional** sealing performance and prolonged service life of valves. Its resistance to high or low temperature, creep or compression, abrasion and corrosion is all outstanding. As an option, KITZ **SWELLESS®** ball seats principally made of PFA are recommended specifically for monomer service. This epoch-making new seat maximizes resistance to the permeation of monomer into its molecular structure (generally known as a "swelling" problem) which causes seat deformation and seriously affects shut-off function of valves in styrene and butadiene monomer service.

Simplified actuator mounting

For 150/300 SCTDZ/UTDZM and SCTA/UTAM Series ball valves, **ISO 5211** actuator mounting pad is integrally provided for uniformly simplified mounting of any actuators provided with valve mounting flanges designed to ISO 5211 dimensional requirement. 150UTBM Series ball valves are provided with KITZ standard integral actuator mounting pad.

Easy maintenance

Split body design for KITZ SCTDZ/UTDZM Series provides the convenience of very easy maintenance critically required for process plants. Body inserts of uni-body, end entry design for KITZ 150/300 SCTA/UTAM Series are threaded into the valve body with provision of unthreading for valve disassembly in case of maintenance operation.

KITZ 150/300 SCTA/UTAM Series Reduced Port, Uni-body, End Entry Ball Valves

This is an illustrated cross-section of a typical KITZ uni-body floating type reduced port ball valve to exhibit the basic design concept. The actual design of a valve may be slightly different from this illustration, depending on its size and pressure class.

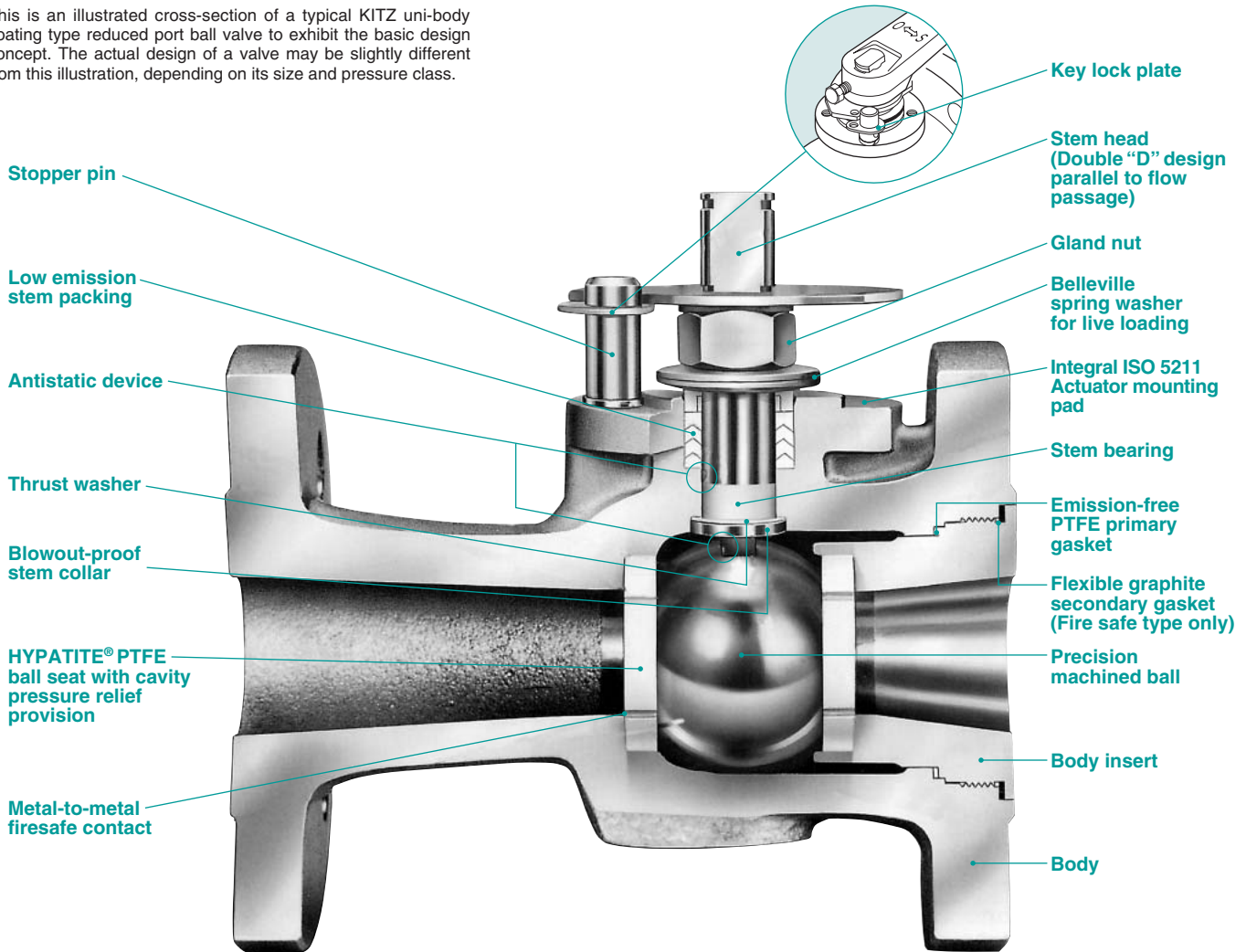

1 1/2" KITZ 150SCTA

Extensive safety considerations

KITZ ball valves are designed with extensive safety considerations for users. Blow-out proof stems, provision of locking devices and prevention of misalignment of lever handles provide safe handling in the field and trouble-free operation in the plant. Antistatic devices, firesafe seal design and cavity pressure relief features all assure the economic benefits of smooth, steady plant operation. KITZ advancements in low emission design features contribute to the global battle against fugitive emissions while greatly reducing costs caused by product loss.

For sour service

Hardness of body, body cap/insert, ball and stem material of KITZ Class 150/300 steel ball valves are controlled by appropriate heat treatment and conformed to the hardness requirements in NACE MR0103, as standard. In addition to the above, following requirements are optionally available.

- Bolting for valves exposed to sour environment.
- NACE requirements for Class 600 and higher steel ball valves.

Please contact KITZ for those requirements.

Seven Safety Considerations for KITZ 150/300 SCTDZ/UTDZM 150UTBM and 150/300 SCTA/UTAM Series Ball Valves

1. **Double "D"** stem head design provides mounting of the lever handle always in parallel to the flow passage. Misalignment of the handle is thus prevented. (Fig. 1)

2. The lower end of the stem is designed with an integral collar to be **blowout-proof**. It also functions as the backseat for assured stem sealing. (Fig. 2)

3. An **antistatic feature** is provided to ensure electrical continuity between ball, stem, and body. (Fig. 2)

4. Facility for mounting a **locking device** for prevention of accidental valve operation is provided.

5. **Plant fires** are a serious concern for soft-seated ball valves because of possible fluid leakage and consequent increase of the fire magnitude caused by deterioration of resilient sealing materials.

KITZ ball valves are engineered for firesafety and successfully **fire tested** to minimize both external and internal fluid leakage after plant fires. They have **post-fire metal-to-metal contact** of all sealing areas such as:

- Contact between ball and valve shell (Fig. 3 & 4)
- Contact between stem and valve shell (Fig. 5 & 6)
- Valve shell coupling flanges of split body design (Fig. 7 & 8)
- Contact between valve body and insert of uni-body design (Fig. 9)

The problem of external fluid leakage is more serious than internal leakage through the valve bore because of the fear of fueling the fire. To prevent this, KITZ ball valves may be ordered with **flexible graphite packing** and **gaskets**, which are extremely heat resistant, and not affected by the fire.

6. The surface of stem and stuffing box, and interface clearance of stem-to-gland, stem-to-body and gland-to-stuffing box are precision controlled on machining and assembly for **low emission service**. A Belleville spring washer is employed for live loading on gland packing rings, to minimize need of gland retightening for **low emission service**.

7. A provision of **cavity pressure relief** is incorporated into precision engineered KITZ **HYPATITE® PTFE** ball seats for the ultimate safety. Refer to Page15 for details.

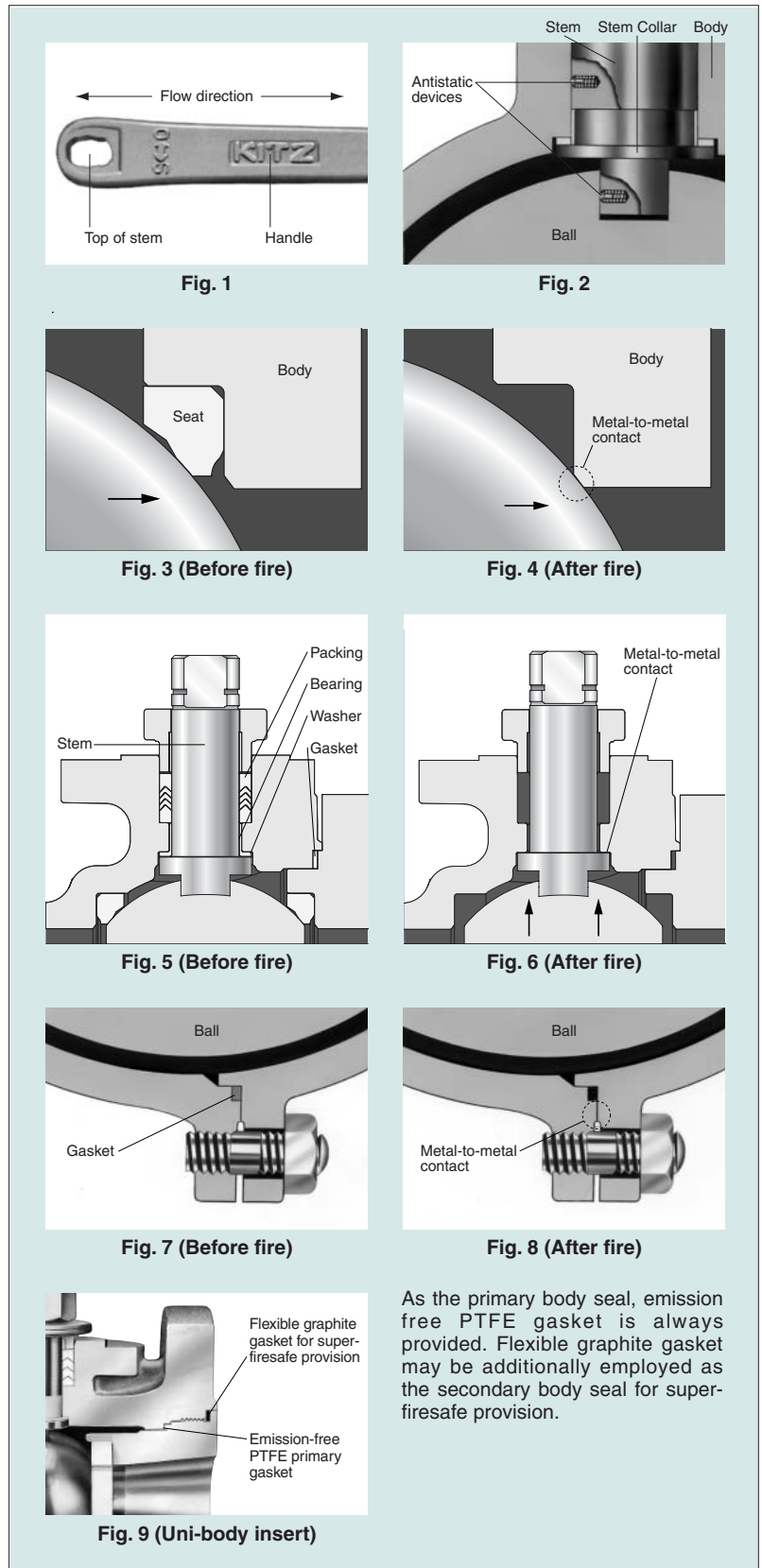

As the primary body seal, emission free PTFE gasket is always provided. Flexible graphite gasket may be additionally employed as the secondary body seal for super-firesafe provision.

Integral Actuator Mounting Pads

KITZ 150/300 SCTDZ/UTDZM series and 150/300 SCTA/UTAM series ball valves are furnished with an integral actuator mounting pad designed and factory-drilled according to ISO 5211 specification. This easily and uniformly enable mounting of any actuators provided with ISO 5211 valve mounting flanges. Mounting pad and stem head dimension also conforms to CAPI ADDS 2.02.

Note: Customers are requested to prepare mounting brackets and connectors for the actuators chosen for their valve automation. Actuators can be mounted on KITZ ball valves without disassembly of valve glands.

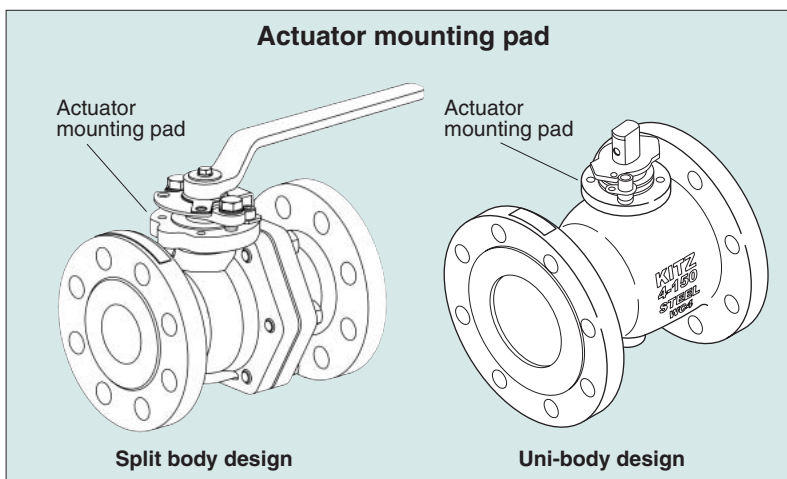

HYPATITE® PTFE Ball Seats

KITZ ball valves are furnished, as the manufacturer's standard, with **HYPATITE® PTFE** ball seats made of denatured PTFE, a molecularly reinforced PTFE copolymer, and specially engineered for high performance which include:

- Wide service temperature range of -29°C (-20°F) through 270°C (518°F) SCTDZ/UTDZM Series, 260°C (500°F) UTB and SCTA/UTAM Series.

This is for standard valve design and materials used for medium to high temperature services. The lower temperature range can be extended down to -196°C (-321°F) by means of extended bonnet design and special low temperature service materials.

- High chemical resistance is comparable to virgin PTFE.
- Monomer permeability is lower than other PTFE materials.
- Resistance against compression and creeping (cold flow) is higher than other PTFE materials to guarantee long life cycle.
- Specific gravity and friction coefficient are equal to those of virgin PTFE for smooth valve operation.
- Purity of processed products is guaranteed as highly as virgin PTFE.
- Resiliency is as high as other PTFE materials for bubble-tight sealing performance.

★ Refer to Page 50 for more technical deta.

Cavity Pressure Relief

Some line fluid is usually left trapped inside the ball-body cavity. This fluid can expand under the influence of high ambient or line temperature. An abnormal increase of such cavity pressure may sometimes damage the valve seats or balls, unless the valve has an adequate cavity pressure relief provision. **Trunnion mounted ball valves generally provide perfect protection from this problem.** Refer to KITZ Cat. No. E-202 for technical details of KITZ trunnion mounted ball valves.

In case of floating ball valves, however, their rather simple seating principle requires some special protection from excessive cavity pressure rise **when highly volatile liquid in service is subject to frequent and large temperature variation, while the valve is not frequently operated.** KITZ 150/300

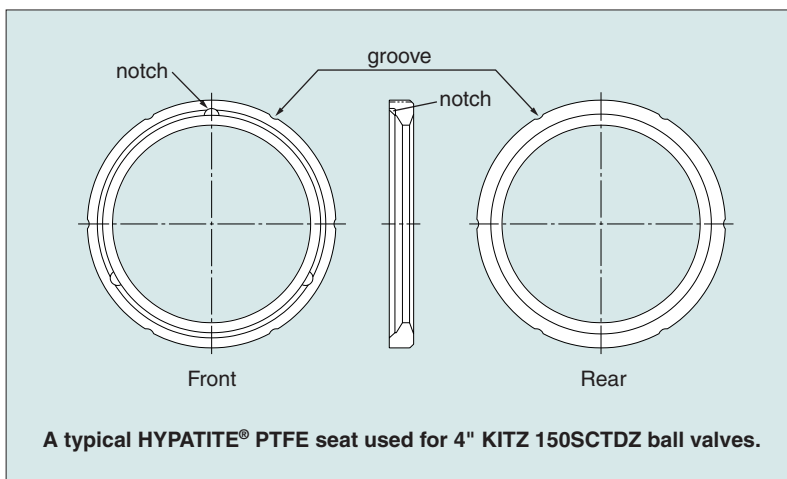

A typical HYPATITE® PTFE seat used for 4" KITZ 150SCTDZ ball valves.

Optional Ball Seats

In addition to the standard **HYPATITE® PTFE** ball seats, **SWELLESS®** seats are recommended for monomer service. Also virgin PTFE and carbon filled PTFE seats are optionally available for versatility in service applications. Refer to Page 16 for details.

SCTDZ/UTDZM and 150/300 SCTA/UTAM Series ball valves offer **self-relieving of excessive cavity pressure** as a standard feature engineered in **HYPATITE® PTFE** ball seats.

Other general solutions for floating ball valves include employment of automatic pressure relief valves or drilling pressure equalization holes on the ball. If the requirement of automatic cavity pressure relief is as critical as in chlorine service, be sure to contact KITZ Corporation or its distributors for technical advice.

This capability is influenced by many variables including: fluid characteristics, variations in pressure, temperature and thermal cycles.

KITZ Ball Seat Materials

The following seat materials are available.

Material	Features	Maximum Service Temperature
Virgin PTFE	High chemical resistance and operation efficiency	200°C
HYPATITE® PTFE	Monomer permeability is lower and resistance against compression and creeping is higher than other PTFE materials	260°C/270°C *1
Carbon filled PTFE	Excellent heat and abrasion resistance	260°C/270°C *1
* FILLTITE®	Highest heat resistance among PTFE based materials	300°C *2
Graphite	Excellent for high temperature service	500°C
Metal	Excellent for high temperature and abrasive service	500°C
PEEK	Higher heat resistance and mechanical strength	270°C
SWELLESS®	Modified PFA excellent for monomer service such as butadiene and styrene	260°C
Glass fiber filled PTFE with MoS₂	Higher abrasion resistance and operation efficiency	230°C
Nylon with MoS₂	Higher mechanical strength	140°C

*: FILLTITE® is a specially reinforced ball seat, made by using more carbon based fillers into PTFE than conventional carbon filled PTFE, which greatly improves heat and abrasion resistance. The material shows excellent operability, durability, chemical resistance and sealing performance at a high temperature of 300°C. In addition, the ball seat is replaceable with the most of our conventional ball seats, so it also has the cost advantage.

*1 270°C: SCTDZ/UTDZM Series only.

*2 Uni-body design: 260°C

Class 150/300 Carbon Steel Ball Valves

Full port, Split body, Side entry design

Features

- Antistatic device
- Blowout-proof stem
- Fire test certification★ (API 607, ISO 10497)
- Stem head conform with CAPI ADDS2.02 dimension
- High performance **HYPATITE® PTFE** ball seats
- Actuator mounting pad to ISO 5211

- Conform to NACE MR0103 for hardness of body, body cap, stem and ball.

Page 7 for Pressure-Temperature Ratings

Page 40 for Construction and Materials

Page 37 for Dimension of Actuator Mounting Pad

150SCTDZ

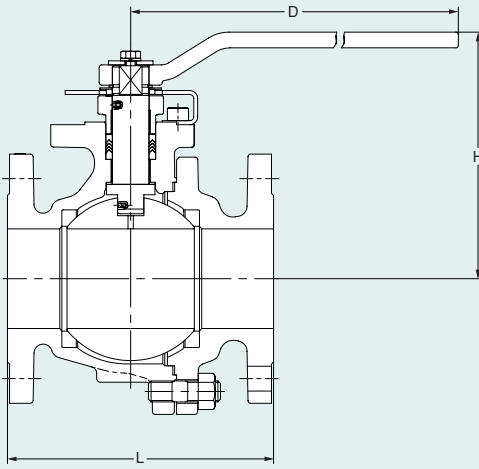

300SCTDZ

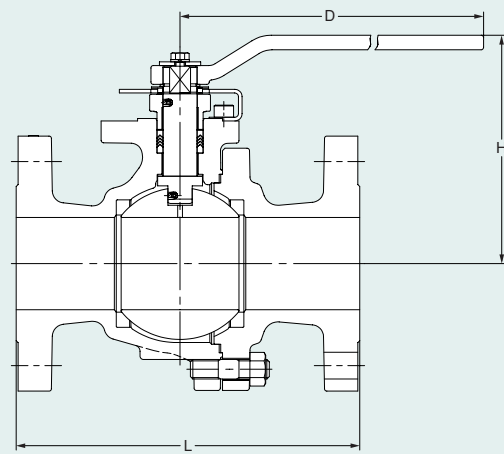

Dimensions of 150SCTDZ

Unit: mm

Valve Size	in.	1/2	3/4	1	1 1/2	2	2 1/2	3	4	5	6	8	10
	mm	15	20	25	40	50	65	80	100	125	150	200	250
Ball Bore		14	19	24	38	50	64	76	100	123	151	202	
L		108	117	127	165	178	190	203	229	356	394	457	
H		108	111	124	134	143	179	189	224	240	315	406	Gear operation
D		130	130	160	230	230	400	400	460	460	1000	1500	Gear operation
ISO 5211 flange type		F03	F03	F05	F07	F07	F10	F10	F12	F12	F14	F16	F16

Dimensions of 300SCTDZ

Unit: mm

Valve Size	in.	1/2	3/4	1	1 1/2	2	2 1/2	3	4	5	6	8
	mm	15	20	25	40	50	65	80	100	125	150	200
Ball Bore		14	19	24	38	50	64	76	100	123	151	202
L		140	152	165	190	216	241	283	305	381	403	502
H		108	111	124	134	143	179	189	251	267	315	406
D		130	130	160	230	230	400	400	750	750	1000	1500
ISO 5211 flange type		F03	F03	F05	F07	F07	F10	F10	F12	F12	F14	F16

Valve operator

- 1/2"~8": Lever operation
- 6"~8": Optional gear operation
- 10: Standard gear operation

Options

- ★ Flexible graphite packing and gasket (See Page 14 and 40)
- Ball and stem to CF8M (316)

Valve operator

- 1/2"~8": Lever operation
- 6"~8": Optional gear operation

Options

- ★ Flexible graphite packing and gasket (See Page 14 and 40)
- Ball and stem to CF8M (316)

Gear Operation

Unit: mm

Class	150	300	Gear Operator							
			H		D		C		A	
			150	300	150	300	150	300	150	300
Valve Size (inch)	6	6	322	335	310	360	165	210	66.5	88.5
	8	8	412	412	360	360	210	210	88.5	88.5
	10		448	—	500	—	363	—	93.5	—

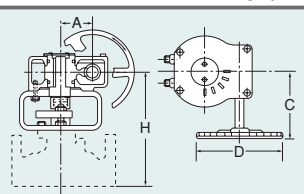

Worm gear operators may be mounted on KITZ ball valves at your option for the smoothest valve operation. Electric or pneumatic actuators are also optionally available. Contact KITZ distributors for appropriate choice and sizing of valve actuators.

Class 150/300 Carbon Steel Ball Valves

Regular port, Uni-body, End entry design

Features

- Antistatic device
- Blowout-proof stem
- Fire test certification★ (API 607)
- Double "D" stem head
- High performance **HYPATITE® PTFE** ball seats
- Actuator mounting pad to ISO 5211

- Conform to NACE MR0103 for hardness of body, body insert, stem and ball.

Page 8 for Pressure-Temperature Ratings

Page 41 for Construction and Materials

Page 38 and 39 for Dimension of Actuator Mounting Pad

150SCTA

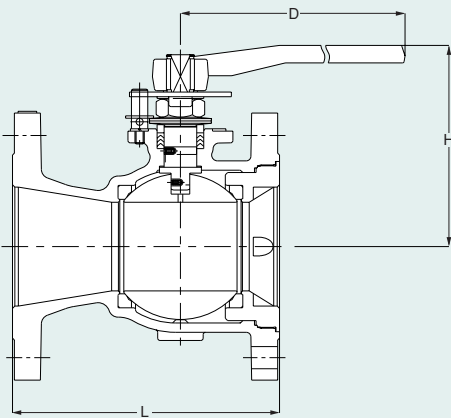

300SCTA

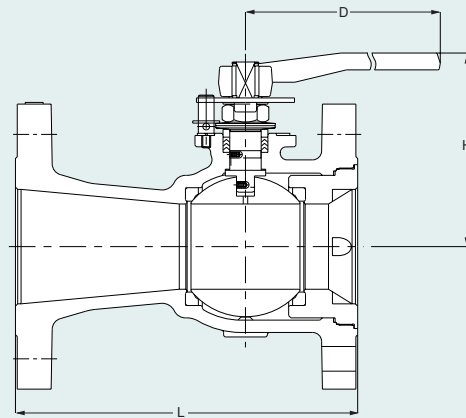

Dimensions of 150SCTA

Valve Size	in.	1/2	3/4	1	1 1/2	2	3	4	6	8	10
	mm	15	20	25	40	50	80	100	150	200	250
Ball Bore		10	12.5	17	30	38	58	76	114	144	187
L		108	117	127	165	178	203	229	267	292	330
H		89	91	100	127	132	197	213	246	293	346
D		140	140	160	180	230	400	400	750	1000	1500

Unit: mm

Dimensions of 300SCTA

Valve Size	in.	1/2	3/4	1	1 1/2	2	3	4	6	8	10
	mm	15	20	25	40	50	80	100	150	200	250
Ball Bore		10	12.5	17	30	38	58	76	114	144	187
L		140	152	165	190	216	283	305	403	419	457
H		89	91	100	127	132	197	213	246	293	346
D		140	140	160	180	230	400	400	750	1000	1500

Unit: mm

Gear Operation

Class		150	300	Gear Operator			
				H	D	C	A
Valve Size (inch)	6	6	257	300	283	71	
	8	8	306	300	283	71	
	10	10	364	400	337	86	

Unit: mm

Valve operator

- 1/2"~10": Lever operation
- 6"~10": Optional gear operation

Options

- ★ Flexible graphite packing and gasket (See Page 14 and 41)
- Ball and stem to CF8M (316)

Valve operator

- 1/2"~10": Lever operation
- 6"~10": Optional gear operation

Options

- ★ Flexible graphite packing and gasket (See Page 14 and 41)
- Ball and stem to CF8M (316)

Worm gear operators may be mounted on KITZ ball valves at your option for the smoothest valve operation. Electric or pneumatic actuators are also optionally available. Contact KITZ distributors for appropriate choice and sizing of valve actuators.

PROVIDED BY: PT. SINAR MAS SAKTI
 TEL: (62 21) 6008088 - FAX: (62 21) 6293410 - EMAIL: sales@smsakti.com

Class 600/1500 Carbon Steel Ball Valves

Full port, Split body, Side entry design

Features

- Antistatic device
- Blowout-proof stem
- Fire test certification★ (API 607)
- Double “D” stem head
- Ball seats: Reinforced PTFE with MoS₂ for Class 600
Nylon with MoS₂ for Class 1500

Page 9 for Pressure-Temperature Ratings

Page 45 and 47 for Construction and Materials

600SCTB

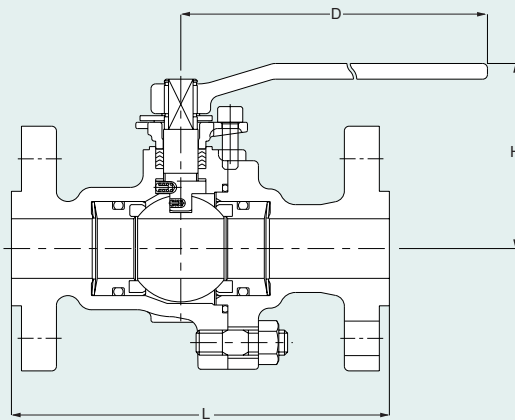

1500SCTB

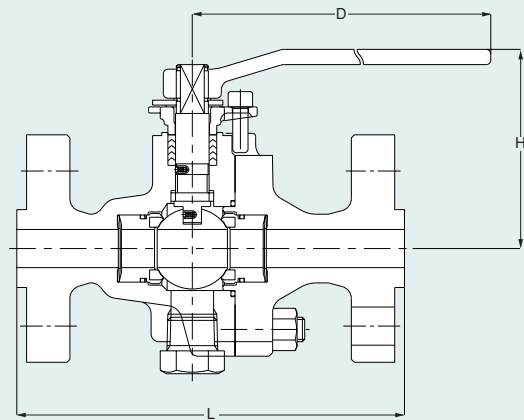

Dimensions of 600SCTB

Unit: mm

Valve Size	in.	1/2	3/4	1	1 1/2
	mm	15	20	25	40
Ball Bore		13	19	25	38
L		165	190	216	241
H		105	108	130	118
D		130	130	160	230

Valve operator
Lever operation

Options

- ★ Flexible graphite packing and flexible graphite spiral wound gasket (See Page 14 and 45)
- Ball and stem to 316

Dimensions of 1500SCTB

Unit: mm

Valve Size	in.	1/2	3/4	1	1 1/2
	mm	15	20	25	40
Ball Bore		13	19	25	38
L		216	229	254	305
H		132	117	123	157
D		160	230	230	400

Valve operator
Lever operation

Options

- ★ Flexible graphite packing and flexible graphite spiral wound gasket (See Page 14 and 47)
- Ball and stem to 316

PROVIDED BY: PT. SINAR MAS SAKTI
 TEL: (62 21) 6008088 - FAX: (62 21) 6293410 - EMAIL: sales@smsakti.com

Class 150/300 Stainless Steel Ball Valves

Full port, Split body, Side entry design

Features

- Antistatic device
- Blowout-proof stem
- Fire test certification★(API 607, ISO 10497)
- Stem head conform with CAPI ADDS 2.02 dimensions
- High performance **HYPATITE® PTFE** ball seats
- Actuator mounting pad to ISO 5211

- Conform to NACE MR0103 for hardness of body, body cap, stem and ball.

Page 7 for Pressure-Temperature Ratings

Page 42 for Construction and Materials

Page 37 for Dimension of Actuator Mounting Pad

150UTDZM

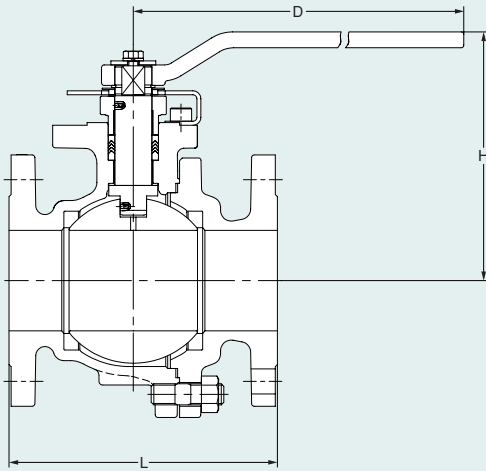

300UTDZM

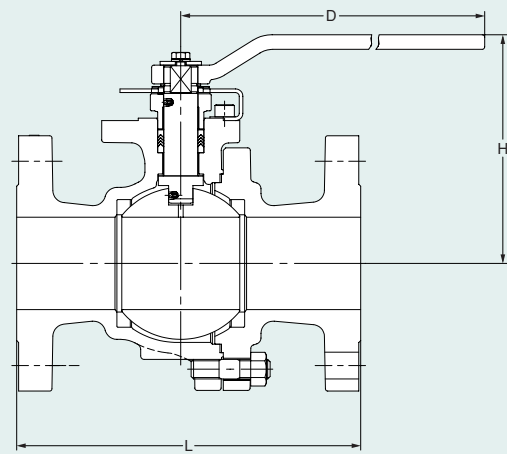

Dimensions of 150UTDZM

Unit: mm

Valve Size	in.	1/2	3/4	1	1 1/4	1 1/2	2	2 1/2	3	4	5	6	8	10
	mm	15	20	25	32	40	50	65	80	100	125	150	200	250
Ball Bore		14	19	24	32	38	50	64	76	100	123	151	202	
L		108	117	127	140	165	178	190	203	229	356	394	457	
H		108	111	124	128	134	143	179	189	224	240	315	406	
D		130	130	160	160	230	230	400	400	460	460	1000	1500	
ISO 5211 flange type		F03	F03	F05	F05	F07	F07	F10	F10	F12	F12	F14	F16	F16

Dimensions of 300UTDZM

Unit: mm

Valve Size	in.	1/2	3/4	1	1 1/4	1 1/2	2	2 1/2	3	4	5	6	8
	mm	15	20	25	32	40	50	65	80	100	125	105	200
Ball Bore		14	19	24	32	38	50	64	76	100	123	151	202
L		140	152	165	178	190	216	241	283	305	381	403	502
H		108	111	124	128	134	143	179	189	251	267	315	406
D		130	130	160	160	230	230	400	400	750	750	1000	1500
ISO 5211 flange type		F03	F03	F05	F05	F07	F07	F10	F10	F12	F12	F14	F16

Valve operator

- 1/2"~8": Lever operation
- 5"~8": Optional gear operation
- 10": Standard gear operation

Option

- ★Flexible graphite packing and gasket (See Page 14 and 42)

Valve operator

- 1/2"~8": Lever operation
- 6"~8": Optional gear operation

Option

- ★Flexible graphite packing and gasket (See Page 14 and 42)

Gear Operation

Unit: mm

Class	150	300	Gear Operator							
			H		D		C		A	
			150	300	150	300	150	300	150	300
Valve Size (inch)	6	6	322	335	310	360	165	210	66.5	88.5
	8	8	412	412	360	360	210	210	88.5	88.5
	10		448	—	500	—	363	—	93.5	—

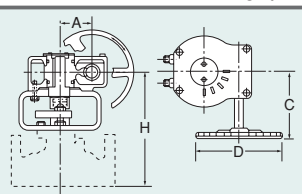

Worm gear operators may be mounted on KITZ ball valves at your option for the smoothest valve operation. Electric or pneumatic actuators are also optionally available. Contact KITZ distributors for appropriate choice and sizing of valve actuators.

PROVIDED BY: PT. SINAR MAS SAKTI
TEL: (62 21) 6008088 - FAX: (62 21) 6293410 - EMAIL: sales@smsakti.com

Class 150 Stainless Steel Ball Valves

Full port, Split body, Side entry design

Features

- Antistatic device
- Blowout-proof stem
- Double "D" stem head
- High performance **HYPATITE® PTFE** ball seats

Page 8 for Pressure-Temperature Ratings

Page 43 for Construction and Materials

150UTBM

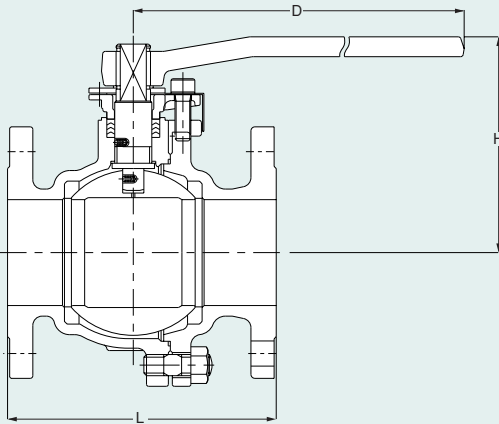

Dimensions of 150UTBM

Unit: mm

Valve Size	in.	1/2	3/4	1	1 1/2	2	2 1/2	3	4	5	6	8	10
	mm	15	20	25	40	50	65	80	100	125	150	200	250
Ball Bore		15	20	25	40	50	65	80	100	125	150	200	250
L		108	117	127	165	178	190	203	229	356	394	457	533
H		102	105	124	115	120	155	165	200	220	295	355	Gear operation
D		130	130	160	230	230	400	400	460	460	1000	1500	Gear operation

Valve operator

1/2" ~ 8": Lever operation
 5" ~ 8": Optional gear operation
 10": Standard gear operation

Gear Operation

Unit: mm

Class	150	Gear Operator			
		H	D	C	A
Valve Size (inch)	5	312	310	165	65.5
	6	337	310	165	65.5
	8	414	360	210	88.5
	10	477	500	363	93.5

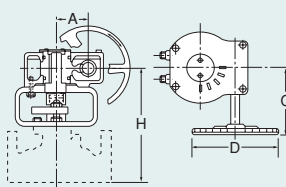

Worm gear operators may be mounted on KITZ ball valves at your option for the smoothest valve operation. Electric or pneumatic actuators are also optionally available. Contact KITZ distributors for appropriate choice and sizing of valve actuators.

PROVIDED BY: PT. SINAR MAS SAKTI
 TEL: (62 21) 6008088 - FAX: (62 21) 6293410 - EMAIL: sales@smsakti.com

Class 150/300 Stainless Steel Ball Valves

Regular port, Uni-body, End entry design

Features

- Antistatic device
- Blowout-proof stem
- Fire test certification★ (API 607)
- Double "D" stem head
- High performance **HYPATITE® PTFE** ball seats
- Actuator mounting pad to ISO 5211

- Conform to NACE MR0103 for hardness of body, body insert, stem and ball.

Page 8 for Pressure-Temperature Ratings

Page 44 for Construction and Materials

Page 38 and 39 for Dimension of Actuator Mounting Pad

150UTAM

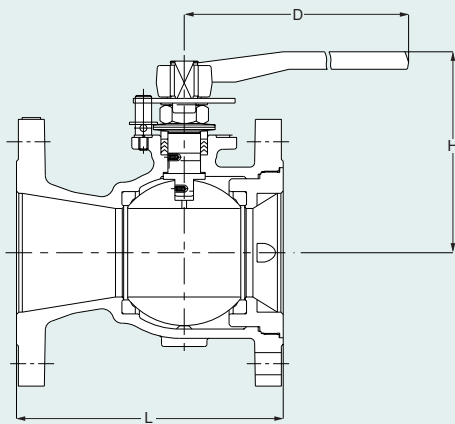

300UTAM

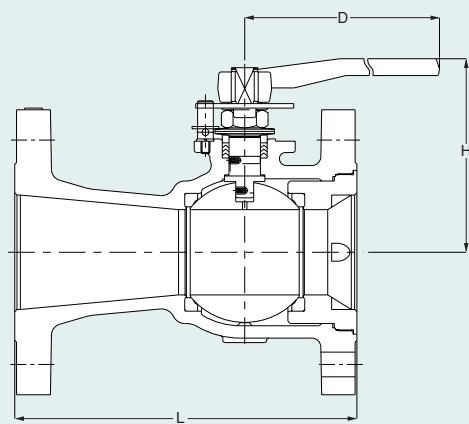

Dimensions of 150UTAM

Valve Size	in.	1/2	3/4	1	1 1/2	2	3	4	6	8	10
	mm	15	20	25	40	50	80	100	150	200	250
Ball Bore		10	12.5	17	30	38	58	76	114	144	187
L		108	117	127	165	178	203	229	267	292	330
H		89	91	100	127	132	197	213	246	293	346
D		140	140	160	180	230	400	400	750	1000	1500

Unit: mm

Dimensions of 300UTAM

Valve Size	in.	1/2	3/4	1	1 1/2	2	3	4	6	8	10
	mm	15	20	25	40	50	80	100	150	200	250
Ball Bore		10	12.5	17	30	38	58	76	114	144	187
L		140	152	165	190	216	283	305	403	419	457
H		89	91	100	127	132	197	213	246	293	346
D		140	140	160	180	230	400	400	750	1000	1500

Unit: mm

Valve operator

- 1/2"~10": Lever operation
- 6"~10": Optional gear operation

Option

- ★ Flexible graphite packing and gasket (See Page 14 and 44)

Valve operator

- 1/2"~10": Lever operation
- 6"~10": Optional gear operation

Option

- ★ Flexible graphite packing and gasket (See Page 14 and 44)

Gear Operation

Class	150	300	Gear Operator			
			H	D	C	A
Valve Size (inch)	6	6	257	300	283	71
	8	8	306	300	283	71
	10	10	364	400	337	86

Unit: mm

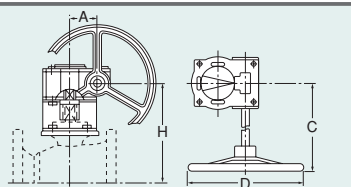

Worm gear operators may be mounted on KITZ ball valves at your option for the smoothest valve operation. Electric or pneumatic actuators are also optionally available. Contact KITZ distributors for appropriate choice and sizing of valve actuators.

Class 600/1500 Stainless Steel Ball Valves

Full port, Split body, Side entry design

Features

- Antistatic device
- Blowout-proof stem
- Fire test certification★ (API 607)
- Double “D” stem head
- Ball seats: Reinforced PTFE with MoS₂ for Class 600
Nylon with MoS₂ for Class 1500

Page 9 for Pressure-Temperature Ratings

Page 46 and 48 for Construction and Materials

600UTBM

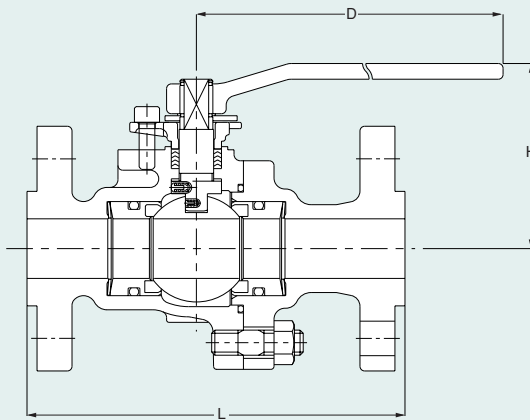

1500UTBM

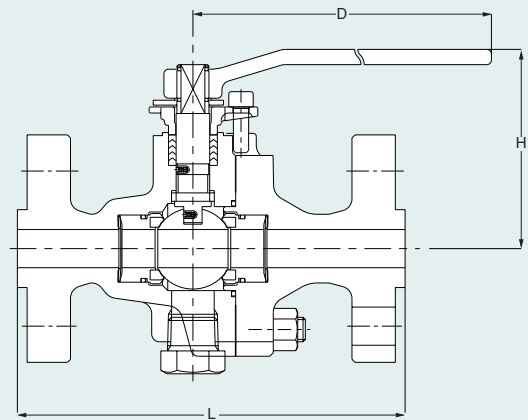

Dimensions of 600UTBM

Unit: mm

Valve Size	in.	1/2	3/4	1	1 1/2
	mm	15	20	25	40
Ball Bore		13	19	25	38
L		165	190	216	241
H		105	108	130	118
D		130	130	160	230

Valve operator
Lever operation

Option

- ★ Flexible graphite packing and flexible graphite spiral wound gasket (See Page 14 and 46)

Dimensions of 1500UTBM

Unit: mm

Valve Size	in.	1/2	3/4	1	1 1/2
	mm	15	20	25	40
Ball Bore		13	19	25	38
L		216	229	254	305
H		132	117	123	157
D		160	230	230	400

Valve operator
Lever operation

Option

- ★ Flexible graphite packing and flexible graphite spiral wound gasket (See Page 14 and 48)

PROVIDED BY: PT. SINAR MAS SAKTI
 TEL: (62 21) 6008088 - FAX: (62 21) 6293410 - EMAIL: sales@smsakti.com

Class 150 Low Temperature Service Ball Valves

Full port, Split body, Side entry design

Features

- Extended bonnet for assured stem seal and freezing prevention.
- Bolted bonnet with body seal gasket.
- Protection of stem alignment by means of two bearings built on top and bottom of stem extension.

Page 9 for Pressure-Temperature Ratings

Lowest working temperature: -104°C

150UTDZXL

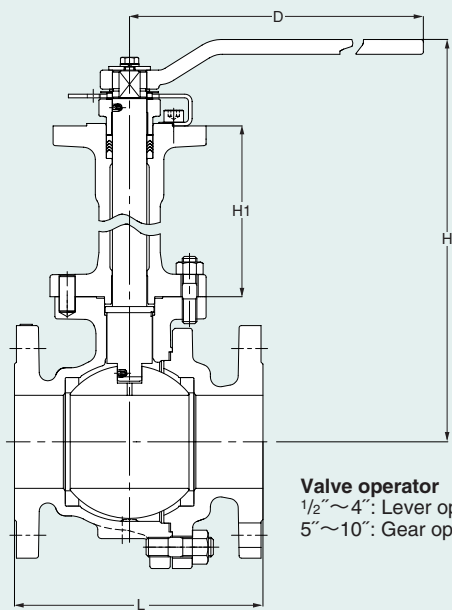

G-150UTDZXL

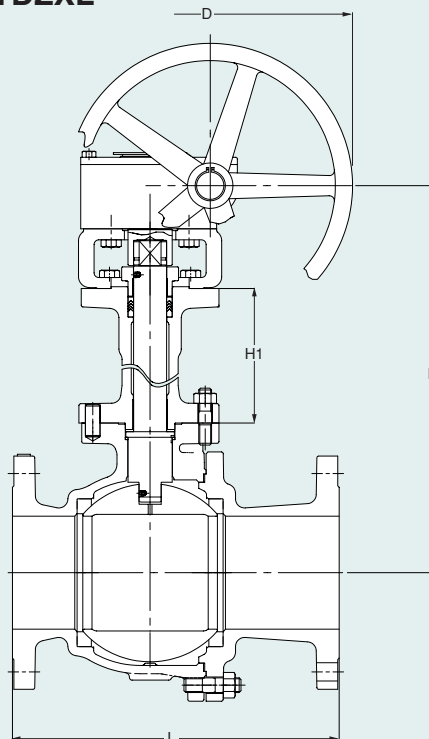

Valve operator
 1/2" ~ 4": Lever operation
 5" ~ 10": Gear operation

Refer to Page 42 for the basic construction and materials.

Dimensions of 150UTDZXL

Valve Size	in.	1/2	3/4	1	1 1/4	1 1/2	2	2 1/2	3	4
	mm	15	20	25	32	40	50	65	80	100
Ball Bore		14	19	24	32	38	50	64	76	100
L		108	117	127	140	165	178	190	203	229
H		228	231	268	272	300	309	373	383	458
H1		120	120	143	143	165	165	194	194	207
D		130	130	160	160	230	230	400	400	750

Unit: mm

Dimensions of G-150UTDZXL

Valve Size	in.	5	6	8	10
	mm	125	150	200	250
Ball Bore		123	151	202	253
L		356	394	457	533
H		482	572	685	724
H1		207	236	268	268
D		310	360	500	500

Unit: mm

Standard materials

Parts	Materials
Body	CF8*
Body cap	CF8*
Bonnet	CF8
Stem	304
Ball	304/CF8
Gland	CF8
Gland packing	PTFE
Ball seat	HYPATITE® PTFE
Gasket	Ceramic filled PTFE
Bonnet bolt/nut	B8/8
Cap bolt/nut	B8/8

* CF8M are available

PROVIDED BY: PT. SINAR MAS SAKTI
 TEL: (62 21) 6008088 - FAX: (62 21) 6293410 - EMAIL: sales@smsakti.com

Class 300 Low Temperature Service Ball Valves

Full port, Split body, Side entry design

Features

- Extended bonnet for assured stem seal and freezing prevention.
- Bolted bonnet with body seal gasket.
- Protection of stem alignment by means of two bearings built on top and bottom of stem extension.

Page 9 for Pressure-Temperature Ratings.

Lowest working temperature: -104°C

300UTDZXL

G-300UTDZXL

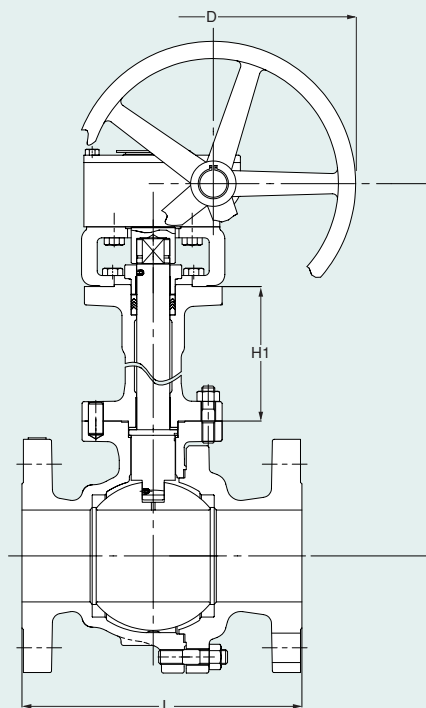
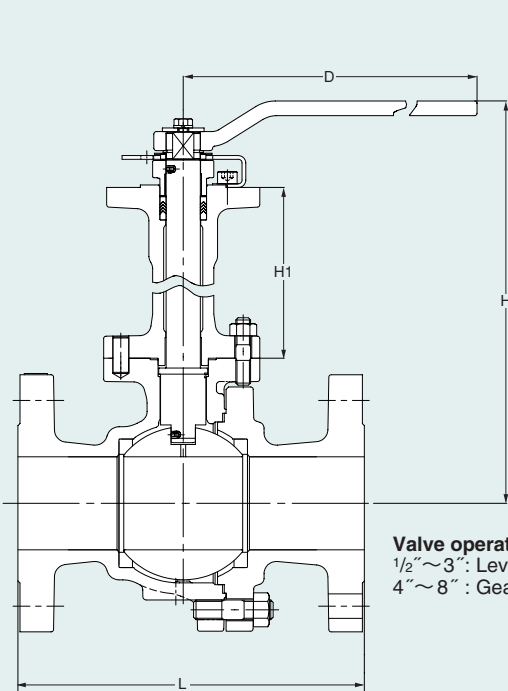

Valve operator
 1/2" ~ 3" : Lever operation
 4" ~ 8" : Gear operation

Refer to Page 42 for the basic construction and materials.

Dimensions of 300UTDZXL

Unit: mm

Valve Size	in.	1/2	3/4	1	1 1/2	2	2 1/2	3
	mm	15	20	25	40	50	65	80
Bore Size		14	19	24	38	50	64	76
L		140	152	165	190	216	241	283
H		228	231	268	300	309	373	383
H1		120	120	143	165	165	194	194
D		130	130	160	230	230	400	400

Dimensions of G-300UTDZXL

Unit: mm

Valve Size	in.	4	6	8
	mm	100	150	200
Bore Size		100	151	202
L		305	403	502
H		466	569	685
H1		207	236	268
D		310	500	500

Standard materials

Parts	Materials
Body	CF8*
Body cap	CF8*
Bonnet	CF8
Stem	304
Ball	304/CF8
Gland	CF8
Gland packing	PTFE
Ball seat	HYPATITE® PTFE
Gasket	Ceramic filled PTFE
Bonnet bolt/nut	B8/8
Cap bolt/nut	B8/8

*CF8M are available

※Valve size 1 1/4" and 5" are available

Class 150 Stainless Steel 3-way Ball Valves

Full port, 2-seated or 4-seated, Split body, Side entry design

Features

- Used for diverting or mixing process media
- One 3-way valve can replace several other valves plus the associated piping pieces
- Antistatic device
- Blowout-proof stem
- Double "D" stem head
- High performance **HYPATITE® PTFE** ball seats
- Actuator mounting pad to KITZ standard

150UTB 2L/2T: Page 7 for Pressure-Temperature Ratings (See UTB Series)

150UTB 4LA/4TA: Page 9 for Pressure-Temperature Ratings

PROVIDED BY: PT. SINAR MAS SAKTI
TEL: (62 21) 6008088 - FAX: (62 21) 6293410 - EMAIL: sales@smsakti.com

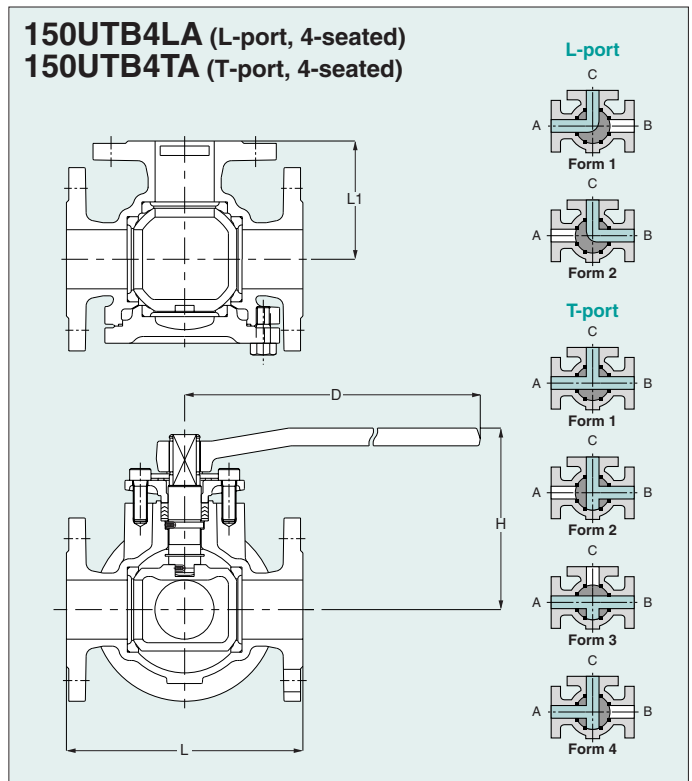
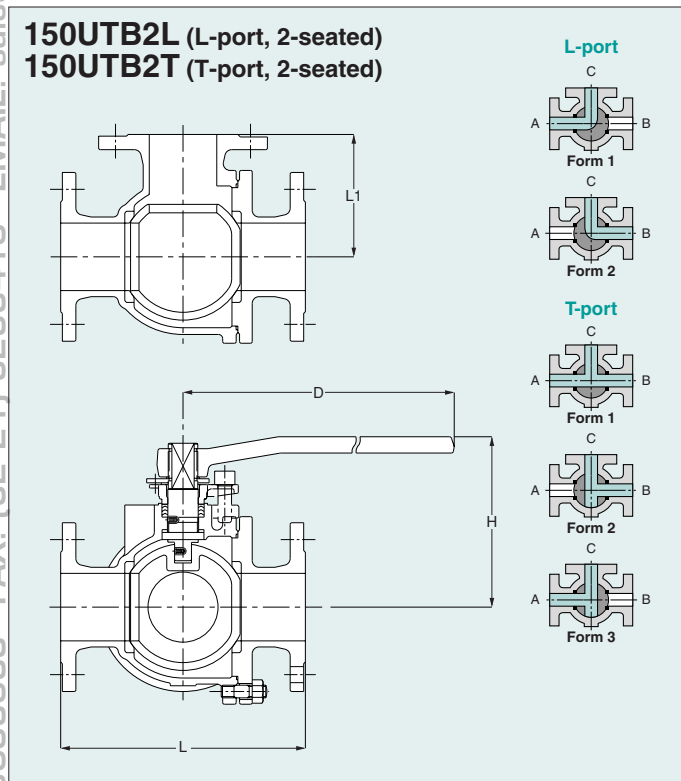

Dimensions of 150UTB2LM/2TM

Valve Size	Unit:mm							
	in.	1	1½	2	2½	3	4	6*
	mm	25	40	50	65	80	100	150
Ball Bore		25	38	51	65	76	102	127
L		165	210	220	250	262	342	437
L1		82.5	105	110	125	131	171	218.5
H		124	115	123	155	165	200	220
D		160	230	230	400	400	460	460

* 150UTR 2LM/2TM

Dimensions of 150UTB4LAM/4TAM

Valve Size	Unit:mm											
	in.	½	¾	1	1½	2	2½	3	4	5*	6*	8*
	mm	15	20	25	40	50	65	80	100	125	150	200
Ball Bore		15	19	25	38	51	64	76	102	100	125	150
L		120	140	160	180	200	242	262	342	348	407	463
L1		65	70	80	90	100	121	131	171	174	203.5	231.5
H		128	132	135	146	155	185	198	267	267	289	335
D		160	160	160	400	400	460	460	1000	1000	1000	1500

* 150UTR 4LAM/4TAM

Valve operator

1"~6": Lever operation
6": Optional gear operation

Note

·JIS 10K type is also available.

Valve operator

½"~8": Lever operation
5"~8": Optional gear operation

Note

·JIS 10K type is also available.

Class 150 Stainless Steel Pocketless Ball Valves

Full port, Split body, Side entry design

Page 8 for Pressure-Temperature Ratings

Features

- Unique filled cavity provides excellent resistance to media build up and/or stagnation between seats
- Antistatic device
- Blowout-proof stem
- Double "D" stem head
- High performance **HYPATITE®** PTFE ball seats
- Actuator mounting pad to KITZ standard

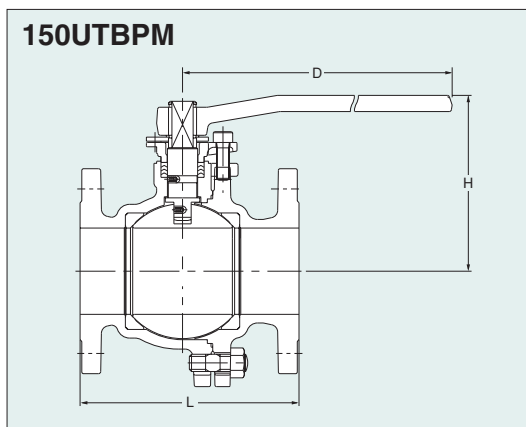

Valve operator

- 1/2"~8": Lever operation
- 5"~8": Optional gear operation

Dimensions

Valve Size	in. mm	Unit: mm										
		1/2	3/4	1	1 1/2	2	2 1/2	3	4	5	6	8
Ball Bore		15	20	25	40	50	65	80	100	125	150	200
L		108	117	127	165	178	190	203	229	356	394	457
H		102	105	124	115	120	155	165	200	220	295	355
D		130	130	160	230	230	400	400	460	460	1000	1500

Class 150 Stainless Steel Jacketed Ball Valves

Full port

Page 8 for Pressure-Temperature Ratings

Features

- Fully jacketed to maintain media temperature
- Antistatic device
- Double "D" stem head
- High performance **HYPATITE®** PTFE ball seats
- Actuator mounting pad to KITZ standard

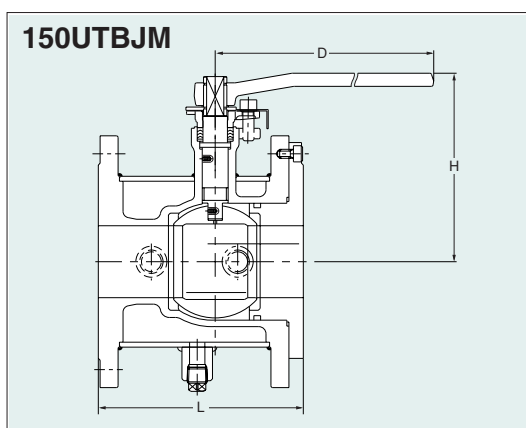

Valve operator

- 1/2"~6": Lever operation
- 6": Optional gear operation

Note

- Maximum allowable pressure is 1.37MPa (199psi) at 260°C (500°F).
- JIS 10K type is also available.

Dimensions

Valve Size	in. mm	Unit: mm									
		1/2	3/4	1	1 1/2	2	2 1/2	3*	4*	6*	
Ball Bore		15	20	25	40	50	65	65	80	125	
L		110	120	130	165	180	190	200	230	270	
H		131	135	150	150	157	188	188	213	258	
D		130	130	160	230	230	400	400	400	460	

* 150UTRJM

Class 150 Stainless Steel Tank Ball Valves

Full port, Split body, Side entry design

Page 8 for Pressure-Temperature Ratings

Features

- Direct mounting to tank bottom
- Churning media evenly
- Antistatic device
- Blowout-proof stem
- Double "D" stem head
- High performance **HYPATITE®** PTFE ball seats
- Actuator mounting pad to KITZ standard

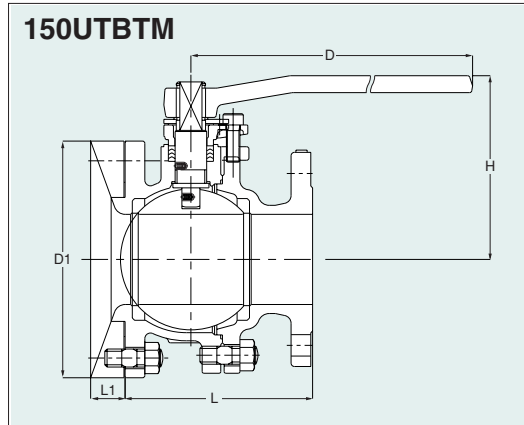

Valve operator

1"~6": Lever operation

Note

- Maximum allowable temperature is 200°C (392°F).
- Class 300 and JIS 10K/20K types are also available.

Dimensions

Unit: mm

Valve Size	in.	1	1½	2	2½	3	4	5	6	8	10
	mm	25	40	50	65	80	100	125	150	200	250
Ball Bore		25	40	50	65	80	100	125	150	For these sizes, please contact KITZ Corporation.	
L		102	125	142	160	171	176	255	292		
H		150	134	143	177	187	222	242	312		
D		160	230	230	400	400	460	460	1000		
L1		35	35	41	43	45	53	53	53		
D1		135	155	175	185	210	280	305	330		

10K Stainless Steel PFA Lined Ball Valves

Full port, Split body, Side entry design

Page 9 for Pressure-Temperature Ratings

Features

- Highly corrosion-resistant PFA lining
- Fine lining without a pinhole
- Highly heat-resistant PFA
- No additives or paints are included
- Double "D" stem head
- High performance **HYPATITE®** PTFE ball seats
- Actuator mounting pad to KITZ standard

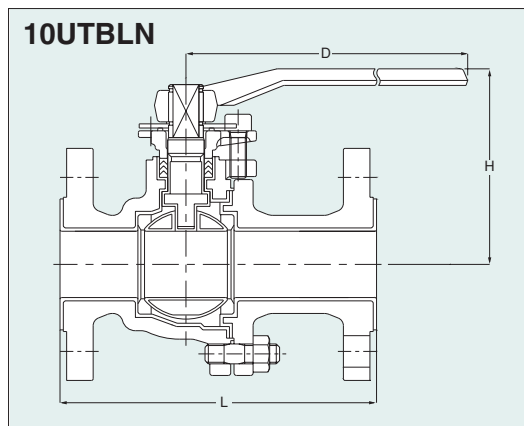

Valve operator

½"~4": Lever operation

Note

- Class 150 type is also available.

Dimensions

Unit: mm

Valve Size	in.	½	¾	1	1½	2	2½	3	4
	mm	15	20	25	40	50	65	80	100
Ball Bore		15	20	25	40	50	65	80	100
L		140	152	165	191	216	240	250	280
H		104	106	129	118	124	157	166	204
D		130	130	160	230	230	400	400	460

Type 600 Carbon Steel Ball Valves

Reduced port, Uni-body design, Threaded ends

Features

- Blowout-proof stem
- Choice of threaded ends:
 - Rc threads to BS 21 (Fig. SCTK)
 - NPT threads to ASME B1.20.1 (Fig. AKSCTK)

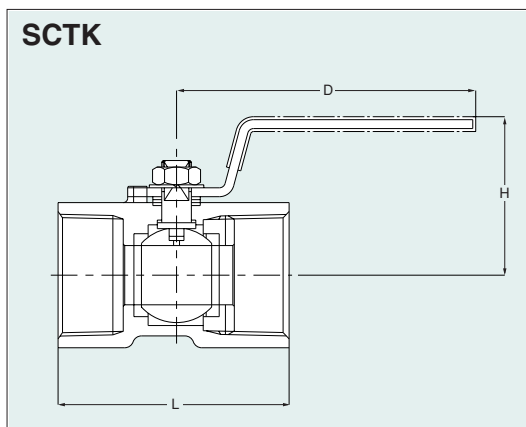

Dimensions

Valve Size	in.	1/4	3/8	1/2	3/4	1	1 1/4	1 1/2	2
		mm	8	10	15	20	25	32	40
Ball Bore		4.5	6.8	9.2	12.5	16	20	24.5	32
L		39	44	56.5	59	71	78	83	100
H		31	36	41	44	48	54	65	72
D		60	70	85	85	100	100	125	125

Unit: mm

Standard materials

Parts	Materials
Body	WCB
Ball	316 or 304 *1
Stem	316 or 304 *2
Ball seat	Glass filled PTFE
Gland packing	Glass filled PTFE
Handle	Plastic covered S.S.

- * 1 304 for 1/2" & larger
- * 2 304 for 3/4" & larger

End-to-end dimensions: KITZ standard

Valve operator

Lever operation
T-type handle as option (3/4" & larger only)

Type 1500/2000 Carbon Steel Ball Valves

Regular port, Split body design, Threaded ends

Features

- Blowout-proof stem
- API 607 firesafe type as option
- NPT threaded ends to ASME B1.20.1

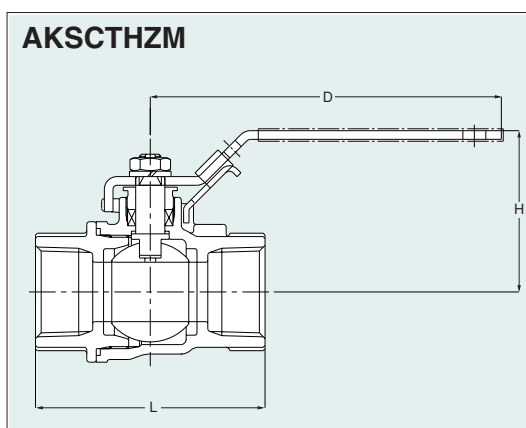

Dimensions

Valve Size	in.	1/4	3/8	1/2	3/4	1	1 1/4	1 1/2	2
		mm	8	10	15	20	25	32	40
Ball Bore		9.5	9.5	10	15	20	25	32	40
L		53	53	62	72	85	94	107	120
H		50.5	50.5	58.5	64	63.5	67.5	83	89
D		100	100	115	115	135	135	155	190

Unit: mm

Page 11 for Pressure-Temperature Ratings

Standard materials

Parts	Materials
Body	WCB
Body cap	WCB
Ball	316
Stem	316
Seat	HYPATITE® PTFE
Gland packing	PTFE *
Gasket	PTFE *
Handle	Plastic covered C.S.

* API 607 firesafe flexible graphite is optionally available.

End-to-end dimensions: KITZ standard

Valve operator

Lever operation with latch lock
Oval handle as option

PROVIDED BY: PT. SINAR MAS SAKTI
 TEL: (62 21) 6008088 - FAX: (62 21) 6293410 - EMAIL: sales@smsakti.com

Type 1500/2000 Carbon Steel Ball Valves

Regular port, Welded body design, Threaded ends

Features

- Blowout-proof stem
- API 607 firesafe type as option
- NPT threaded ends to ASME B1.20.1

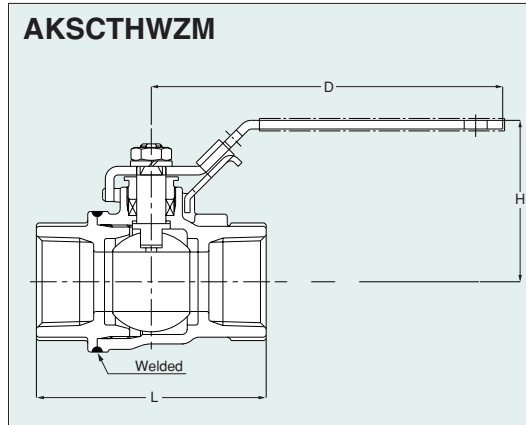

Dimensions

Valve Size	in.	1/4	3/8	1/2	3/4	1	1 1/4	1 1/2	2
		mm	8	10	15	20	25	32	40
Ball Bore		9.5	9.5	10	15	20	25	32	40
L		53	53	62	72	85	94	107	120
H		50.5	50.5	58.5	64	63.5	67.5	83	89
D		100	100	115	115	135	135	155	190

Unit: mm

Standard materials

Parts	Materials
Body	WCB
Body cap	WCB
Ball	316
Stem	316
Seat	HYPATITE® PTFE
Gland packing	PTFE*
Gasket	PTFE*
Handle	Plastic covered C.S.

* API 607 firesafe flexible graphite is optionally available.

End-to-end dimensions: KITZ standard

Valve operator

Lever operation with latch lock
Oval handle as option

Class 800 and Type 3000 Carbon Steel Ball Valves

Regular port, Welded body design, Threaded ends

Features

- Antistatic device
- Blowout-proof stem
- Fire test certification★
- Choice of threaded ends:
 - Rc threads to BS 21 (Fig. 800/3000 SCKT)
 - NPT threads to ASME B1.20.1 (Fig. AK800/3000 SCKT)

Note

1. Class 800 ball valves are designed to BS 5351.
2. Type 3000 ball valves are designed to KITZ standard for servicing water, oil and gaseous fluid under the maximum working pressure of 3000psi.

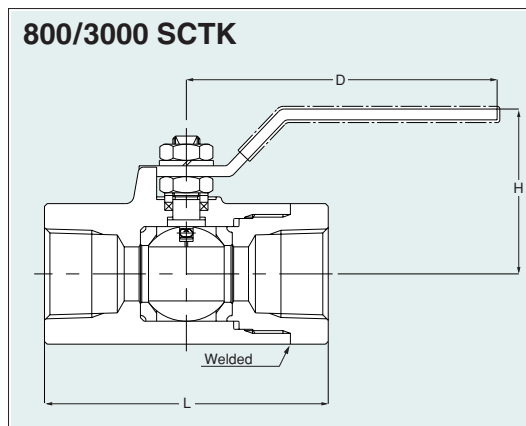

Dimensions

Valve Size	in.	1/4	3/8	1/2	3/4	1	1 1/4	1 1/2	2
		mm	8	10	15	20	25	32	40
Ball Bore		10	10	10	15	20	25	32	38
L		88	88	88	90	105	117	130	150
H		44	44	44	54	57	64	69	80
D	Class 800	100	100	100	115	115	135	135	150
	Type 3000	100	100	100	115	115	160	160	230

Unit: mm

Page 10 for Pressure-Temperature Ratings

Standard materials

Parts	Materials
Body	A105
Body cap	A105
Stem	316 (Class 800) 329 (Type 3000)
Ball	316
Gland packing	PTFE
Ball seat	PTFE (Class 800) PCTFE* (Type 3000)

* Polychloro-Trifluoro-Ethylene.

Valve operator

Lever operation

Option

★ Flexible graphite packing and gasket.

Class 800 and Type 3000 Carbon Steel Ball Valves

Regular port, Split body design, Socket welding ends

Page 10 for Pressure-Temperature Ratings

Features

- Antistatic device
- Blowout-proof stem
- Fire test certification★
- Socket welding ends to ASME B16.11

Note

1. Class 800 ball valves are designed to BS 5351.
2. Type 3000 ball valves are designed to KITZ standard for servicing water, oil and gaseous fluid under the maximum working pressure of 3000psi.

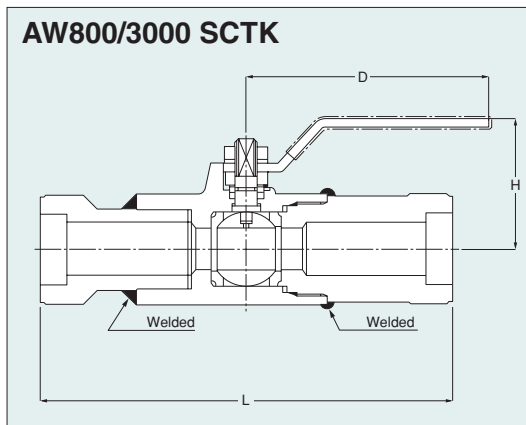

Standard materials

Parts	Materials
Body	A105
Body cap	A105
Stem	316 (Class 800) 329 (Type 3000)
Ball	316
Gland packing	Flexible graphite
Ball seat	PTFE (Class 800) PCTFE* (Type 3000)

* Polychloro-Trifluoro-Ethylene.

End-to-end dimensions: KITZ standard

Valve operator

Lever operation

Option

- ★ Flexible graphite packing and gasket.

Dimensions

Valve Size	in.	1/4	3/8	1/2	3/4	1	1 1/4	1 1/2	2
		mm	8	10	15	20	25	32	40
Ball Bore		10	10	10	15	20	25	32	38
L		170	170	170	176	196	210	226	262
H		44	44	44	54	57	65	70	81
D	Class 800	100	100	100	115	115	135	135	150
	Type 3000	100	100	100	115	115	160	160	230

Unit: mm

Type 1000 Carbon Steel Ball Valves

Full port, Three-piece body design, Threaded or socket welding ends

Page 10 for Pressure-Temperature Ratings

Features

- Blowout-proof stem
- Swing-away body for maintenance ease
- Choice of threaded ends:
 - Rc threads to BS 21 (Fig. SC3TZF)
 - NPT threads to ASME B1.20.1 (Fig. AKSC3TZF)
- Socket welding ends to BS 5351 (Fig. SWSC3TZF)
- Socket welding ends to ASME B16.11 (Fig. AWSC3TZF)

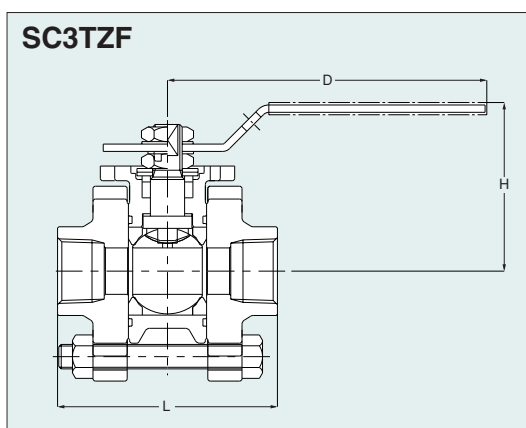

Standard materials

Parts	Materials
Body	WCB
Body cap	WCB
Ball	CF8M/316
Stem	316
Seat	HYPATITE® PTFE
Gland packing	PTFE
Gasket	PTFE
Handle	Plastic covered S.S.

End-to-end dimensions: KITZ standard

Valve operator

Lever operation
Oval handle as option

Note

- Use SC3TZ for size 2".

Dimensions

Valve Size	in.	1/4	3/8	1/2	3/4	1	1 1/4	1 1/2
		mm	8	10	15	20	25	32
Ball Bore		10	10	14	19	24	30	38
L		63	63	71	90	103	110	127
H		48	48	60	69	82	88	104
D		120	120	130	130	150	150	180

Unit: mm

Type 1000 Carbon Steel Ball Valves

Regular port, Three-piece body design, Threaded or socket welding ends

Page 10 for Pressure-Temperature Ratings

Features

- Blowout-proof stem
- Swing-away body for maintenance ease
- Choice of threaded ends:
 - Rc threads to BS 21 (Fig. SC3TZ)
 - NPT threads to ASME B1.20.1 (Fig. AKSC3TZ)
 - Socket welding ends to BS 5351 (Fig. SWSC3TZ)
 - Socket welding ends to ASME B16.11 (Fig. AWSC3TZ)

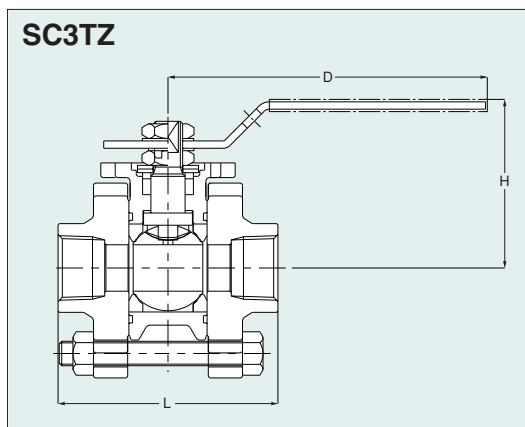

Standard materials

Parts	Materials
Body	WCB
Body cap	WCB
Ball	CF8M/316
Stem	316
Seat	HYPATITE® PTFE
Gland packing	PTFE
Gasket	PTFE
Handle	Plastic covered S.S.

End-to-end dimensions: KITZ standard

Valve operator

Lever operation
Oval handle as option

Note

• Use SC3TZF for sizes 1/4" & 3/8".

Dimensions

Valve Size	Unit: mm						
	in.	1/2	3/4	1	1 1/4	1 1/2	2
	mm	15	20	25	32	40	50
Ball Bore		10	14	19	24	30	38
L		63	71	90	103	110	127
H		48	60	69	83	88	104
D		120	130	130	150	150	180

Type 600 Stainless Steel Ball Valves

Reduced port, Uni-body design, Threaded ends

Page 10 for Pressure-Temperature Ratings

Features

- Blowout-proof stem
- Choice of threaded ends:
 - Rc threads to BS 21 (Fig. UTKM)
 - NPT threads to ASME B1.20.1 (Fig. AKUTKM)

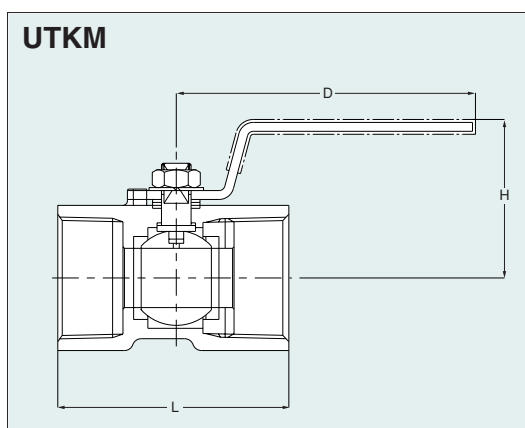

Standard materials

Parts	Materials
Body	CF8M
Ball	316
Stem	316
Seat	Glass filled PTFE
Gland packing	Reinforced PTFE
Handle	Plastic covered S.S.

End-to-end dimensions: KITZ standard

Valve operator

Lever operation
T-type handle as option

Dimensions

Valve Size	Unit: mm								
	in.	1/4	3/8	1/2	3/4	1	1 1/4	1 1/2	2
	mm	8	10	15	20	25	32	40	50
Ball Bore		4.5	6.8	9.2	12.5	16	20	24.5	32
L		39	44	56.5	59	71	78	83	100
H		31	36	41	44	48	54	65	75
D		60	70	85	85	100	100	125	125

Type 800 Stainless Steel Ball Valves

Regular port, Split body design, Threaded ends

Features

- Blowout-proof stem
- Choice of threaded ends:
 - Rc threads to BS 21 (Fig. UTHM)
 - NPT threads to ASME B1.20.1 (Fig. AKUTHM)

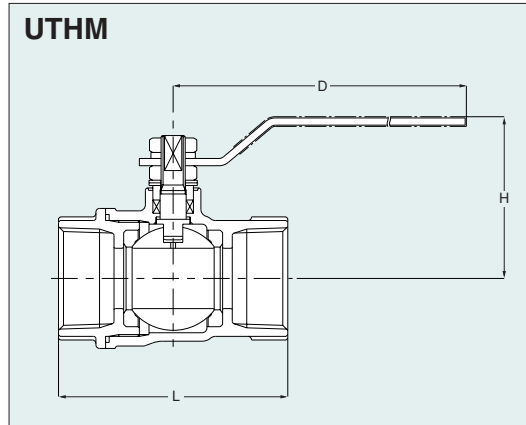

Dimensions

Unit: mm

Valve Size	in.	1/2	3/4	1	1 1/4	1 1/2	2
	mm	15	20	25	32	40	50
Ball Bore		10	15	20	25	32	40
L		60	70	80	95	108	124
H		49	54	64	68	79	85
D		100	100	130	130	150	150

Standard materials

Parts	Materials
Body	CF8M
Body cap	CF8M
Ball	316
Stem	316 Cr plated
Seat	PTFE
Gland packing	PTFE
Handle	Plastic covered S.S.

End-to-end dimensions: KITZ standard

Valve operator
Lever operation

Type 1500 Stainless Steel Ball Valves

Full port, Split body design, Threaded ends

Features

- Blowout-proof stem
- Choice of threaded ends:
 - Rc threads to BS 21 (Fig. UTFM)
 - NPT threads to ASME B1.20.1 (Fig. AKUTFM)

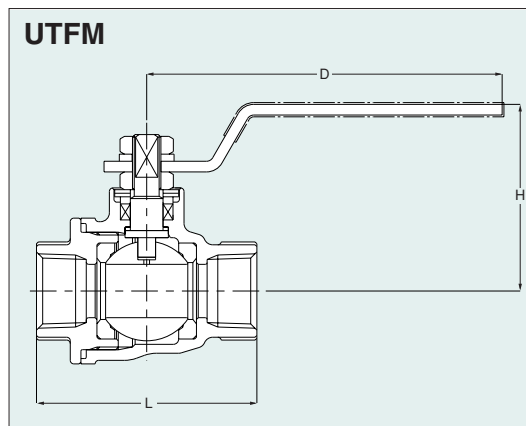

Dimensions

Unit: mm

Valve Size	in.	1/2	3/4	1	1 1/4	1 1/2	2
	mm	15	20	25	32	40	50
Ball Bore		15	20	25	32	40	50
L		62	73	85	98	108	124
H		53	63	67	75	81	102
D		100	130	130	150	150	200

Standard materials

Parts	Materials
Body	CF8M
Body cap	CF8M
Ball	316
Stem	316 Cr plated
Seat	HYPATITE® PTFE
Gland packing	PTFE
Gasket	PTFE
Handle	Plastic covered S.S.

End-to-end dimensions: KITZ standard

Valve operator
Lever operation

Type 1500/2000 Stainless Steel Ball Valves

Regular port, Split body design, Threaded ends

Features

- Blowout-proof stem
- API 607 firesafe type as option
- NPT threads to ASME B1.20.1

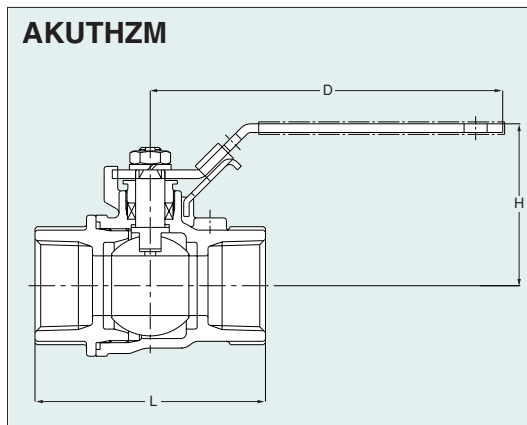

Dimensions

Valve Size	in.	1/4	3/8	1/2	3/4	1	1 1/4	1 1/2	2
		mm	8	10	15	20	25	32	40
Ball Bore		9.5	9.5	10	15	20	25	32	40
L		53	53	62	72	85	94	107	120
H		50.5	50.5	58.5	64	63.5	67.5	83	89
D		100	100	115	115	135	135	155	190

Unit: mm

Standard materials

Parts	Materials
Body	CF8M
Body cap	CF8M
Ball	316
Stem	316
Seat	HYPATITE® PTFE
Gland packing	PTFE
Gasket	PTFE
Handle	Plastic covered S.S.

* API 607 firesafe flexible graphite is optionally available.

End-to-end dimensions: KITZ standard

Valve operator

Lever operation with latch lock
Oval handle as option

Type 1500/2000 Stainless Steel Ball Valves

Regular port, Welded body design, Threaded ends

Features

- Blowout-proof stem
- API 607 firesafe type as option
- NPT threads to ASME B1.20.1

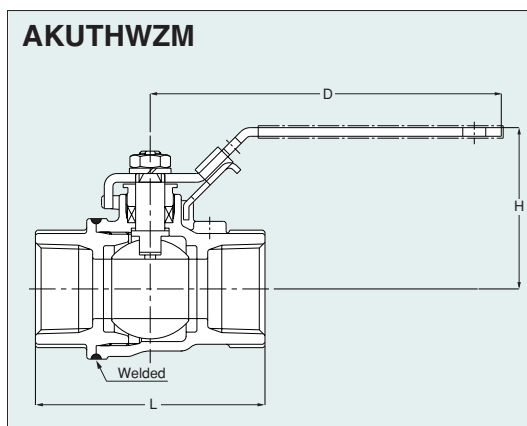

Dimensions

Valve Size	in.	1/4	3/8	1/2	3/4	1	1 1/4	1 1/2	2
		mm	8	10	15	20	25	32	40
Ball Bore		9.5	9.5	10	15	20	25	32	40
L		53	53	62	72	85	94	107	120
H		50.5	50.5	58.5	64	63.5	67.5	83	89
D		100	100	115	115	135	135	155	190

Unit: mm

Page 11 for Pressure-Temperature Ratings

Standard materials

Parts	Materials
Body	CF8M
Body cap	CF8M
Ball	316
Stem	316
Seat	HYPATITE® PTFE
Gland packing	PTFE
Gasket	PTFE
Handle	Plastic covered S.S.

* API 607 firesafe flexible graphite is optionally available.

End-to-end dimensions: KITZ standard

Valve operator

Lever operation with latch lock
Oval handle as option

Type 1000 Stainless Steel Ball Valves

Full port, 3-pce body design, Threaded or socket welding ends

Features

- Blowout-proof stem
- Swing-away body for maintenance ease
- Choice of threaded ends:
 - Rc threads to BS 21 (Fig. U3TZFM)
 - NPT threads to ASME B1.20.1 (Fig. AKU3TZFM)
 - Socket welding ends to BS 5351 (Fig. SWU3TZFM)
 - Socket welding ends to ASME B16.11 (Fig. AWU3TZFM)

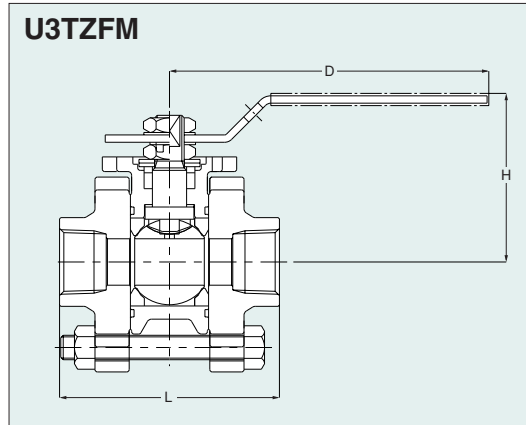

Dimensions

Valve Size	Unit: mm							
	in.	1/4	3/8	1/2	3/4	1	1 1/4	1 1/2
	mm	8	10	15	20	25	32	40
Ball Bore		10	10	14	19	24	30	38
L		63	63	71	90	103	110	127
H		48	48	60	69	82	88	104
D		120	120	130	130	150	150	180

Page 10 for Pressure-Temperature Ratings

Standard materials

Parts	Materials
Body	CF8M
Body cap	CF8M
Ball	316 or CF8M
Stem	316
Seat	HYPATITE® PTFE
Gland packing	PTFE
Gasket	PTFE
Handle	Plastic covered S.S.

End-to-end dimensions: KITZ standard

Valve operator

- Lever operation
- Oval handle as option

Note

- Use U3TZM for size 2".

Type 1000 Stainless Steel Ball Valves

Regular port, 3-pce body design, Threaded or socket welding ends

Features

- Blowout-proof stem
- Swing-away body for maintenance ease
- Choice of threaded ends:
 - Rc threads to BS 21 (Fig. U3TZM)
 - NPT threads to ASME B1.20.1 (Fig. AKU3TZM)
 - Socket welding ends to BS 5351 (Fig. SWU3TZM)
 - Socket welding ends to ASME B16.11 (Fig. AWU3TZM)

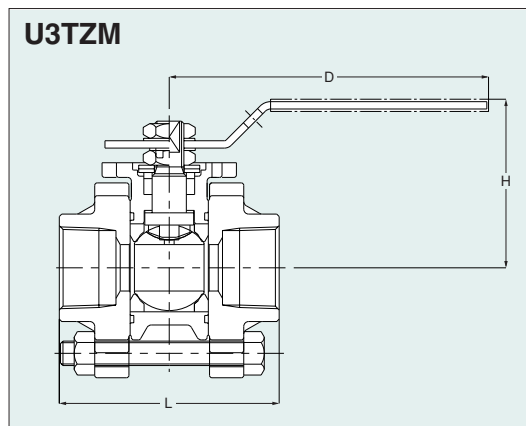

Dimensions

Valve Size	Unit: mm						
	in.	1/2	3/4	1	1 1/4	1 1/2	2
	mm	15	20	25	32	40	50
Ball Bore		10	14	19	24	30	38
L		63	71	90	103	110	127
H		48	60	69	83	88	104
D		120	130	130	150	150	180

Page 10 for Pressure-Temperature Ratings

Standard materials

Parts	Materials
Body	CF8M
Body cap	CF8M
Ball	316 or CF8M
Stem	316
Seat	HYPATITE® PTFE
Gland packing	PTFE
Gasket	PTFE
Handle	Plastic covered S.S.

End-to-end dimensions: KITZ standard

Valve operator

- Lever operation
- Oval handle as option

Note

- Use U3TZFM for sizes 1/4" & 3/8".

Type 800 Stainless Steel 3-way Ball Valves

Regular port, 4-seated, Split body, Threaded ends

Page 10 for Pressure-Temperature Ratings

- L-port and T-port
- Rc threads to BS 21

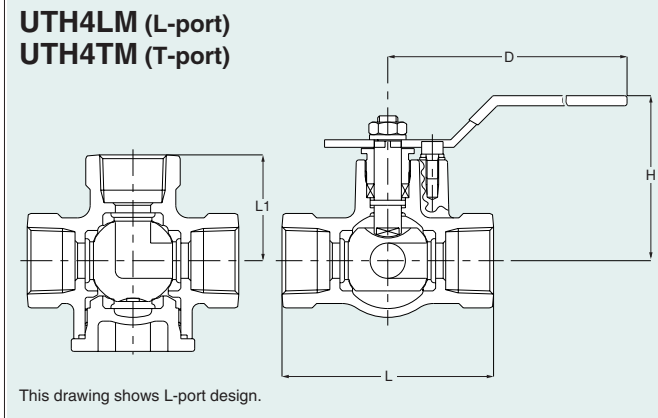
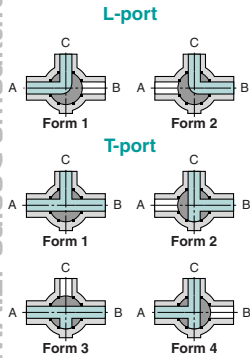

Standard materials

Parts	Materials
Body	CF8M
Body cap	CF8M
Ball	316 or CF8M
Stem	316
Seat	HYPATITE® PTFE
Gland packing	PTFE
Gasket	PTFE
Handle	Plastic covered S.S.

End-to-end dimensions: KITZ standard

Valve operator

Lever operation

Dimensions

Valve Size	Unit: mm						
	in.	1/2	3/4	1	1 1/4	1 1/2	2
	mm	15	20	25	32	40	50
Ball Bore		10	14	19	25	32	38
L		69	84	96	114	132	150
L1		34.5	42	48	57	66	75
H		63	65	75.5	79.5	95.5	101
D		130	130	150	150	230	230

Class 150 Stainless Steel Ball Valves

Full port, Split body, Side entry design, Threaded ends

Page 11 for Pressure-Temperature Ratings

- Choice of threaded ends:
 - Rc threads to BS 21 (Fig. 150UTM)
 - NPT threads to ASME B1.20.1 (Fig. AK150UTM)

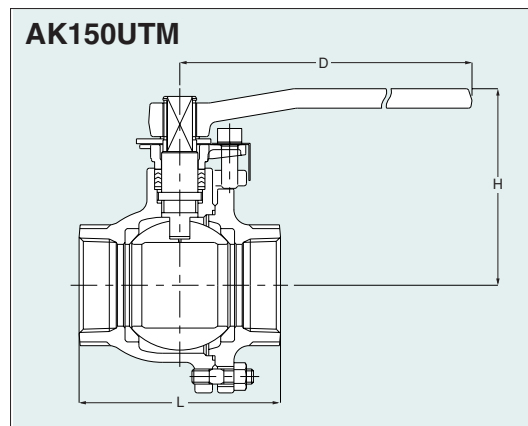

Standard materials

Parts	Materials
Body	CF8M
Body cap	CF8M
Ball	316
Stem	316 or CF8M
Seat	PTFE
Gland packing	PTFE
Gasket	PTFE
Handle	Plastic covered S.S.

End-to-end dimensions: KITZ standard
Wall thickness: ASME B16.34 Class 150

Dimensions

Valve Size	Unit: mm									
	in.	3/8	1/2	3/4	1	1 1/4	1 1/2	2	2 1/2	3
	mm	10	15	20	25	32	40	50	65	80
Ball Bore		10	15	20	25	32	40	50	65	80
L		62	65	80	90	110	120	140	160	182
H		71	102	105	124	130	115	120	155	165
D		130	130	130	160	160	230	230	400	400

Valve operator

Lever operation

Note

• JIS 10K type is also available.

PROVIDED BY: PT. SINAR MAS SAKTI
 TEL: (62 21) 6008088 - FAX: (62 21) 6293410 - EMAIL: sales@smsakti.com

Dimensions of ISO 5211 Actuator Mounting Pad for Class 150 / 300 Full Port, Split Body, Side Entry Design Ball Valves

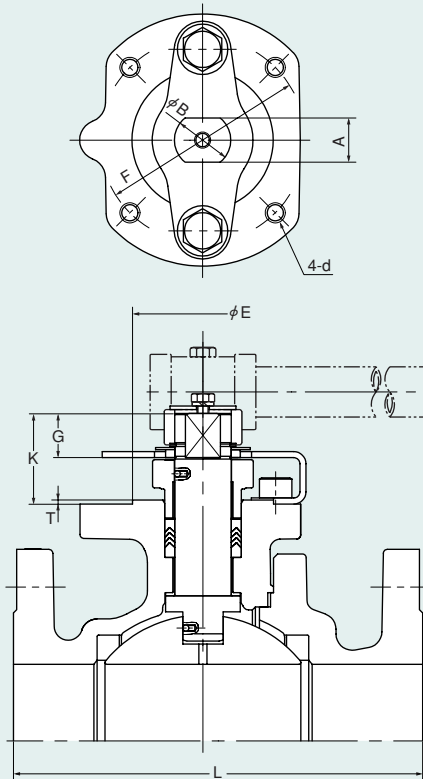

PROVIDED BY: PT. SINAR MAS SAKTI
TEL: (62 21) 6008088 - FAX: (62 21) 6293410 - EMAIL: sales@smsakti.com

Dimensions

Unit: mm

Class	Nominal size (in.)	-0.05 -0.10 A	-0.1 -0.2 φ B	-0.1 -0.2 φ E	±0.2 -0.2 φ F	G	K	L	d	T	ISO 5211 Flange Type
									M thread		
150	1/2	9	12	25	36	9	22	108	M5	1	F03
	3/4	9	12	25	36	9	22	117	M5	1	F03
	1	14	18	35	50	14	30	127	M6	1.5	F05
	1 1/4	14	18	35	50	14	30	140	M6	1.5	F05
	1 1/2	17	22	55	70	17	34	165	M8	1.5	F07
	2	17	22	55	70	17	34	178	M8	1.5	F07
	2 1/2	22	28	70	102	22	45	190	M10	2	F10
	3	22	28	70	102	22	45	203	M10	2	F10
	4	27	36	85	125	27	52	229	M12	2	F12
	5	27	36	85	125	27	52	356	M12	2	F12
300	6	36	48	100	140	36	63	394	M16	2	F14
	8	46	60	130	165	46	79	457	M20	2	F16
	10	46	60	130	165	46	79	533	M20	2	F16
	1/2	9	12	25	36	9	22	140	M5	1	F03
	3/4	9	12	25	36	9	22	152	M5	1	F03
	1	14	18	35	50	14	30	165	M6	1.5	F05
	1 1/2	17	22	55	70	17	34	190	M8	1.5	F07
	2	17	22	55	70	17	34	216	M8	1.5	F07
	2 1/2	22	28	70	102	22	45	241	M10	2	F10
	3	22	28	70	102	22	45	283	M10	2	F10
4	27	36	85	125	27	52	305	M12	2	F12	
6	36	48	100	140	36	63	403	M16	2	F14	
8	46	60	130	165	46	79	502	M20	2	F16	

*** KITZ product codes:**

- (1) 150UTDZ (4) 300SCTDZ
- (2) 150SCTDZ (5) 150UTDZXL
- (3) 300UTDZ (6) 300UTDZXL

Note: Dimension of stem head are in accordance with CAPI ADDS 2.02, but the maximum specified dimension in CAPI ADDS 2.02 is "F14".
For NPS 8 and 10, mounting pads are F16/ISO 5211.

Dimensions of ISO 5211 Actuator Mounting Pad for Class 150 / 300 Regular Port, Uni-body, End Entry Design Ball Valves

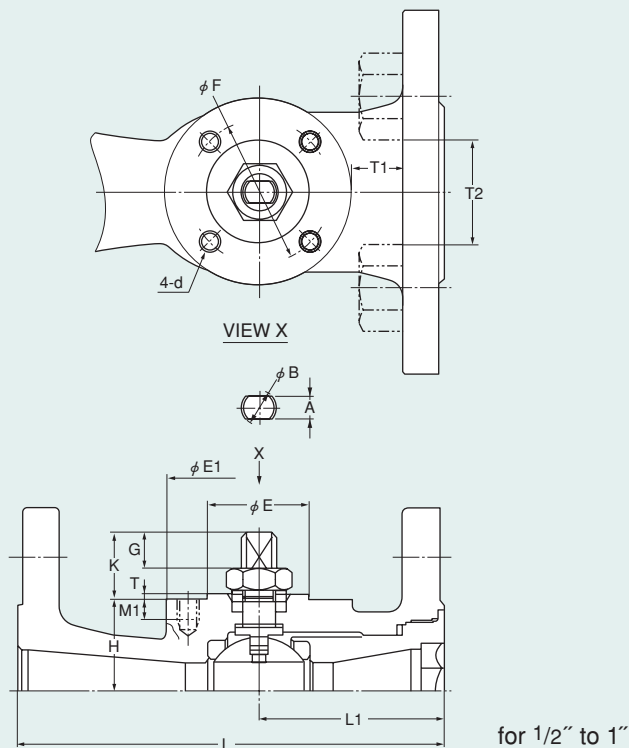

Dimensions

Unit: mm

Class	Nominal size (in.)	-0.02 -0.06 A	-0.1 -0.2 φ B	-0.1 -0.2 φ E	φ E1	±0.2 φ F	G	H	K	L	L1	d		M1	T	T1	T2	ISO 5211 flange type
												M thread	UNC thread★					
150	1/2	7*	10	25	48	36	7.2	18.5	16	108	48	M5	1/4-20 UNC	6	1.5	11.5	17	F03
	3/4	7*	10	25	48	36	7.2	21	16	117	48	M5	1/4-20 UNC	6	1.5	11.5	24	F03
	1	9	12	25	55	36	10	27	21.5	127	55	M5	1/4-20 UNC	6	1.5	14	30.5	F03
300	1/2	7*	10	25	48	36	7.2	18.5	16	140	52	M5	1/4-20 UNC	6	1.5	12	21.5	F03
	3/4	7*	10	25	48	36	7.2	21	16	152	57	M5	1/4-20 UNC	6	1.5	14	27	F03
	1	9	12	25	55	36	10	27	21.5	165	62	M5	1/4-20 UNC	6	1.5	14	31.5	F03

* These dimensions are specified as F03S by CAPI.

★ UNC threads optionally available.

KITZ product codes:

150SCTA
150UTAM
300SCTA
300UTAM

PROVIDED BY: PT. SINAR MAS SAKTI
TEL: (62 21) 6008088 - FAX: (62 21) 6293410 - EMAIL: sales@smsakti.com

Dimensions of ISO 5211 Actuator Mounting Pad for Class 150 / 300 Regular Port, Uni-body, End Entry Design Ball Valves

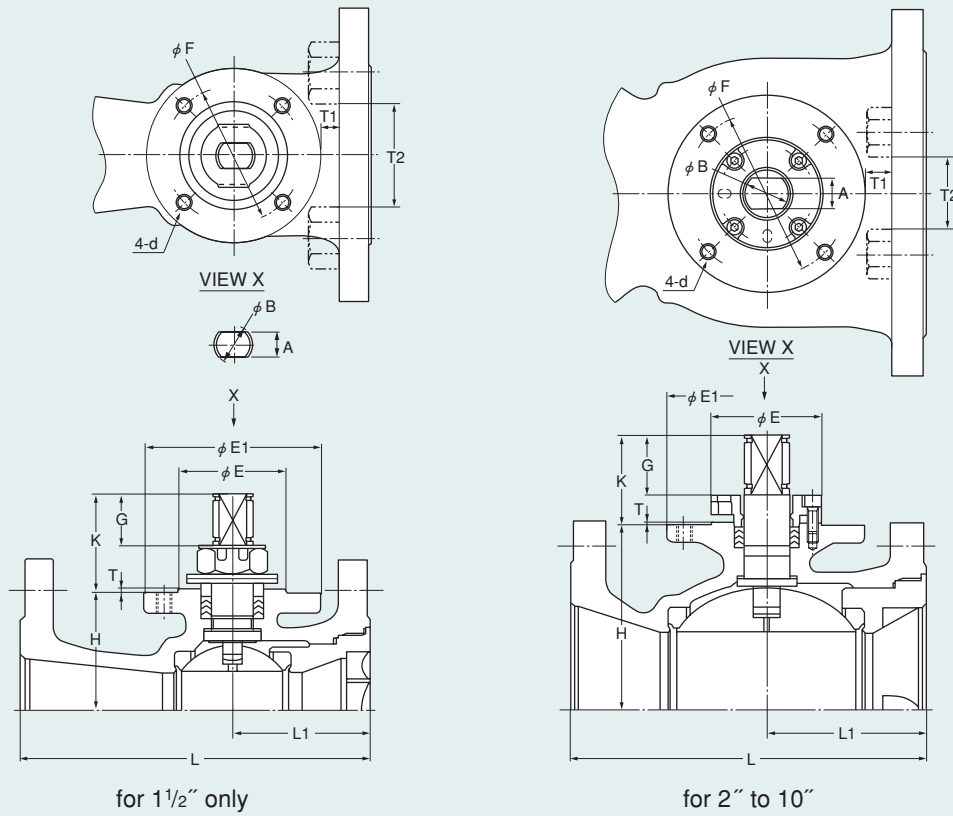

Dimensions

Unit: mm

Class	Nominal size (in.)	-0.02 -0.07 A	-0.1 -0.2 φ B	-0.1 -0.2 φ E	φ E1	±0.2 φ F	G	H	K	L	L1	d		T	T1	T2	ISO 5211 flange type
												M thread	UNC thread★				
150	1 1/2	14	18	35	65	50	14	48	32	165	58	M6	1/4-20 UNC	2	9.5	44	F05
	2	17	22	55	90	70	17	59	34	178	70	M8	5/16-18 UNC	2	6	54	F07
	3	22	28	70	125	102	22	102	45	203	75	M10	3/8-16 UNC	2	8	76.5	F10
	4	22	28	70	125	102	22	118	45	229	85	M10	3/8-16 UNC	2	13	41.5	F10
	6	27	36	85	150	125	27	136.5	50	267	120	M12	1/2-13 UNC	2	16.5	—	F12
	8	36	48	100	175	140	36	166	63	292	131	M16	5/8-11 UNC	2	12	—	F14
	10	46	60	130	210	165	46	202	78	330	164	M20	3/4-10 UNC	2	27	—	F16
300	1 1/2	14	18	35	65	50	14	48	32	190	65	M6	1/4-20 UNC	2	9	44	F05
	2	17	22	55	90	70	17	59	34	216	90	M8	5/16-18 UNC	2	19.5	17.5	F07
	3	22	28	70	125	102	22	102	45	283	98	M10	3/8-16 UNC	2	21.5	27.5	F10
	4	22	28	70	125	102	22	118	45	305	100	M10	3/8-16 UNC	2	20.5	39.5	F10
	6	27	36	85	150	125	27	136.5	50	403	138	M12	1/2-13 UNC	2	23.5	33	F12
	8	36	48	100	175	140	36	166	63	419	158	M16	5/8-11 UNC	2	26	43	F14
	10	46	60	130	210	165	46	202	78	457	189	M20	3/4-10 UNC	2	33.5	28	F16

KITZ product codes:
150SCTA
150UTAM
300SCTA
300UTAM

★UNC threads optionally available.

PROVIDED BY: PT. SINAR MAS SAKTI
 TEL: (62 21) 6008088 - FAX: (62 21) 6293410 - EMAIL: sales@smsakti.com

Construction and Materials

No.	Parts	Standard		Super-firesafe	
		150SCTDZ 300SCTDZ		150SCTDZ-FS 300SCTDZ-FS	
1	Body*1	A216 Gr.WCB			
2	Body cap*1	A216 Gr.WCB			
3	Stem	A276 Type 304*5			
4	Ball*2	A276 Type 304 or A351 Gr.CF8			
7	Gland	A351 Gr.CF8			
8	Gland packing	PTFE		Flexible graphite	
9	Handle*3	Ductile iron			
9A	Handle bar*3	Carbon steel			
9B	Handle head*3	Ductile iron			
16	Name plate	A276 Type 304*5			
19	Gasket	PTFE		Flexible graphite	
20	Packing washer*4	A276 Type 316L*6			
30	Ball seat	HYPATITE® PTFE			
33	Cap nut	A194 Gr.2H			
35	Cap bolt	A193 Gr.B7			
36	Gland bolt	Stainless steel			
40	Keylock plate	A276 Type 304*5			
43	Handle-lock plate	A276 Type 304*5			
48	Snap ring	A276 Type 304*5			
49	Stopper	A276 Type 304*5			
51	Stopper plate	A276 Type 304*5			
57	Gland bush	Reinforced PTFE			
58	Gland washer	A276 Type 304*5			
67	Stem bearing	Reinforced PTFE			
123A	Handle-lock plate bolt	Stainless steel			
123B	Handle bolt	Stainless steel			
124	Spring & pin	A313 & A276 Type 316			
126	Stopper plate bolt	Stainless steel			
145	Coned disc spring	Stainless steel			

■ Standard material configuration can be applied to sour service.

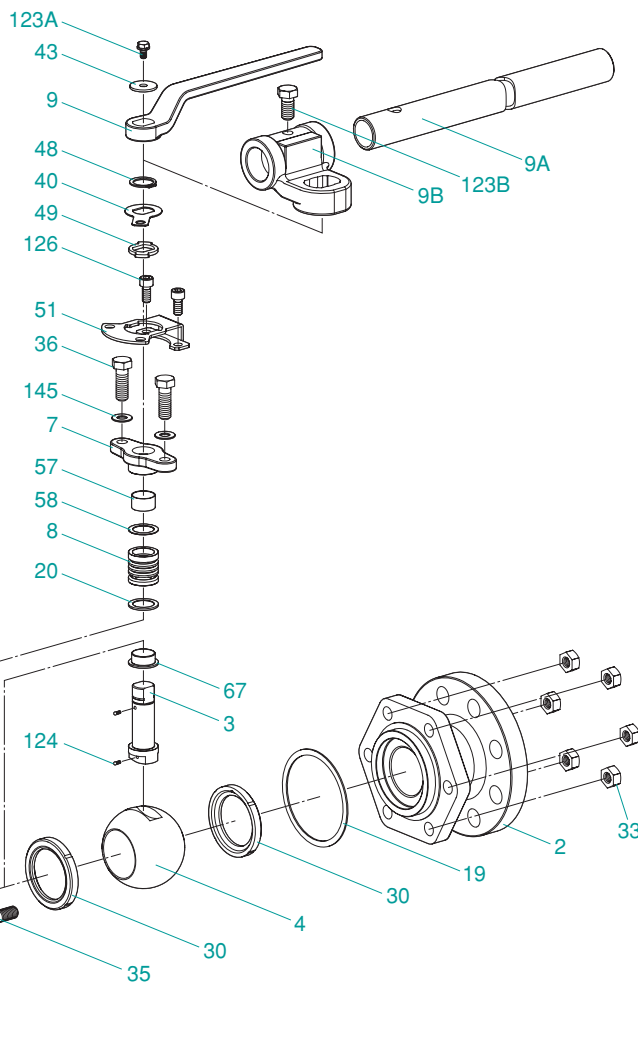

*1 A352 Gr. LCC low-temperature service materials are optionally available.

*2 CF8M or Type 316 is optionally available for balls & stems.

*3 Class 150: Bar type handle used for size 6" & 8".

Class 300: Bar type handle used for size 4" to 8".

*4 Up to size 1".

*5 A276 Type 304 or equal.

*6 A276 Type 316 or equal.

All part numbers are corresponding with those shown in valve assembly drawings.

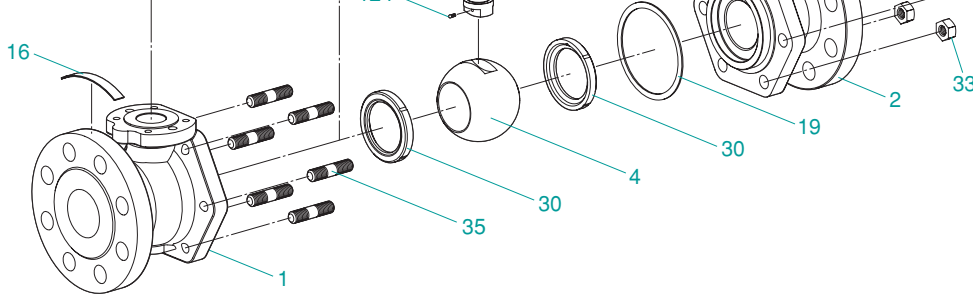
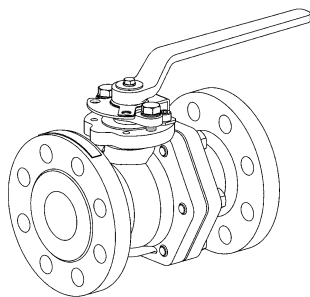
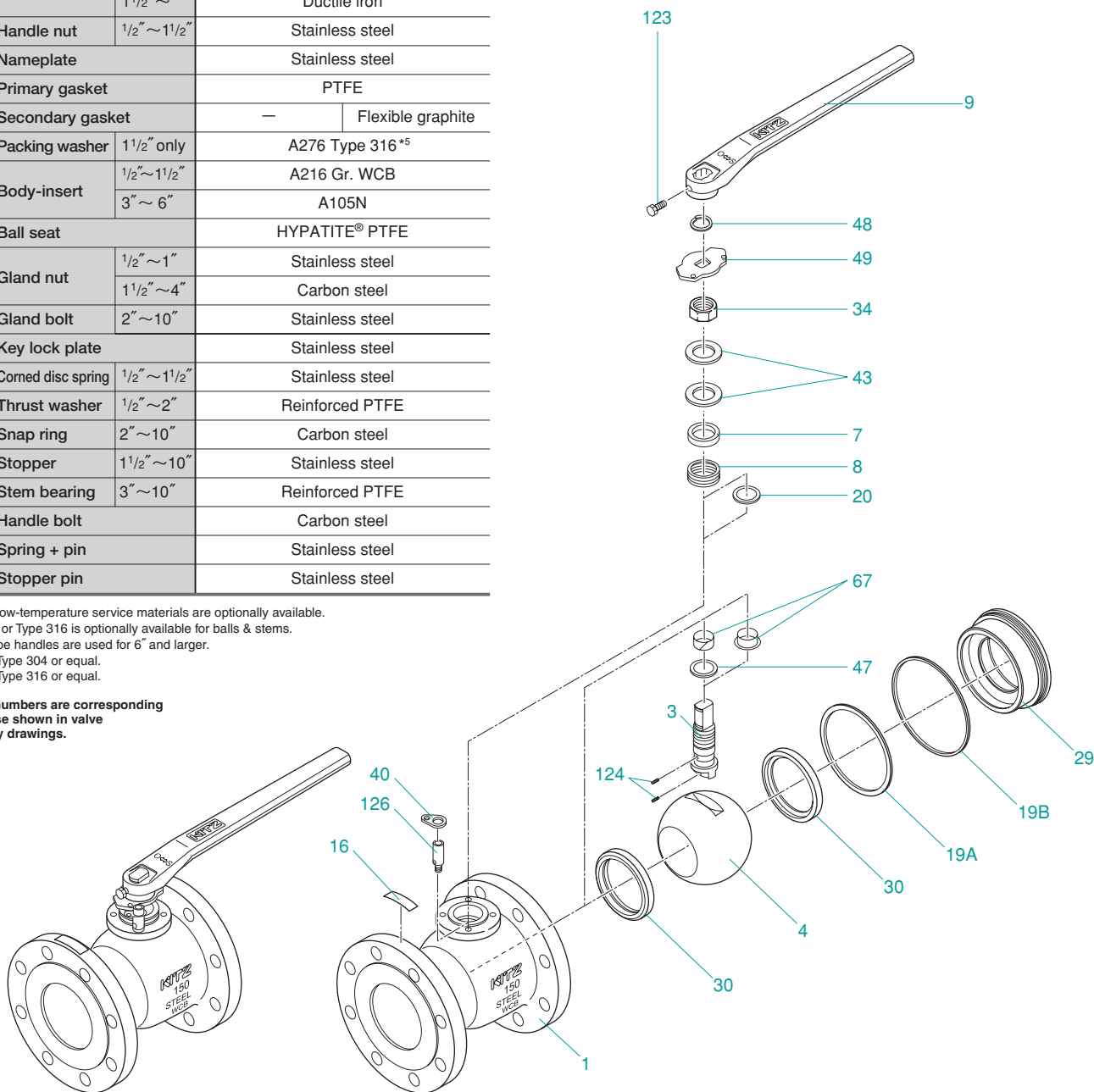

Illustration shows Size 4 design.

Construction and Materials

No.	Parts	Standard		Super-firesafe
		150SCTA 300SCTA	150SCTA-FS 300SCTA-FS	150SCTA-FS 300SCTA-FS
1	Body	A216 Gr. WCB*1		
3	Stem	A276 Type 304*2 *4		
4	Ball	A276 Type 304 / A351 Gr. CF8		
7	Gland	1/2" ~ 1 1/2"	A276 Type 316 *5	
		2" ~ 10"	A351 Gr. CF8	
8	Gland packing	PTFE	Flexible graphite	
9	Handle*3	1/2" ~ 1"	Carbon steel	
		1 1/2" ~	Ductile iron	
10	Handle nut	1/2" ~ 1 1/2"	Stainless steel	
16	Nameplate	Stainless steel		
19A	Primary gasket	PTFE		
19B	Secondary gasket	—	Flexible graphite	
20	Packing washer	1 1/2" only	A276 Type 316 *5	
29	Body-insert	1/2" ~ 1 1/2"	A216 Gr. WCB	
		3" ~ 6"	A105N	
30	Ball seat	HYPATITE® PTFE		
34	Gland nut	1/2" ~ 1"	Stainless steel	
		1 1/2" ~ 4"	Carbon steel	
36	Gland bolt	2" ~ 10"	Stainless steel	
40	Key lock plate	Stainless steel		
43	Comed disc spring	1/2" ~ 1 1/2"	Stainless steel	
47	Thrust washer	1/2" ~ 2"	Reinforced PTFE	
48	Snap ring	2" ~ 10"	Carbon steel	
49	Stopper	1 1/2" ~ 10"	Stainless steel	
67	Stem bearing	3" ~ 10"	Reinforced PTFE	
123	Handle bolt	Carbon steel		
124	Spring + pin	Stainless steel		
126	Stopper pin	Stainless steel		

■ Standard material configuration can be applied to sour service.



*1 A352 low-temperature service materials are optionally available.

*2 CF8M or Type 316 is optionally available for balls & stems.

*3 Bar type handles are used for 6" and larger.

*4 A276 Type 304 or equal.

*5 A276 Type 316 or equal.

All part numbers are corresponding with those shown in valve assembly drawings.

Illustration shows Size 1 1/2" design.

KITZ Steel Ball Valves, Floating Ball Design

Construction and Materials

■ Standard material configuration can be applied to sour service.

No.	Parts	Standard		Super-firesafe	
		150UTDZ 300UTDZ	150UTDZM 300UTDZM	150UTDZ-FS 300UTDZ-FS	150UTDZM-FS 300UTDZM-FS
1	Body	A351 Gr.CF8	A351 Gr.CF8M	A351 Gr.CF8	A351 Gr.CF8M
2	Body cap	A351 Gr.CF8	A351 Gr.CF8M	A351 Gr.CF8	A351 Gr.CF8M
3	Stem	A276 Type 304	A276 Type 316	A276 Type 304	A276 Type 316
4	Ball*2	A276 Type 304 or A351 Gr.CF8	A276 Type 316 or A351 Gr.CF8M	A276 Type 304 or A351 Gr.CF8	A276 Type 316 or A351 Gr.CF8M
7	Gland	A351 Gr.CF8			
8	Gland packing	PTFE		Flexible graphite	
9	Handle*3	Ductile iron			
9A	Handle bar*3	Carbon steel			
9B	Handle head*3	Ductile iron			
16	Name plate	A276 Type 304*4			
19	Gasket	PTFE		Flexible graphite	
20	Packing washer*4	A276 Type 316L*5			
30	Ball seat	HYPATITE® PTFE			
33	Cap nut	A194 Gr.8			
35	Cap bolt	A193 Gr.B8			
36	Gland bolt	Stainless steel			
40	Keylock plate	A276 Type 304*4			
43	Handle-lock plate	A276 Type 304*4			
48	Snap ring	A276 Type 304*4			
49	Stopper	A276 Type 304*4			
51	Stopper plate	A276 Type 304*4			
57	Gland bush	Reinforced PTFE			
58	Gland washer	A276 Type 304*4			
67	Stem bearing	Reinforced PTFE			
123A	Handle-lock plate bolt	Stainless steel			
123B	Handle bolt	Stainless steel			
124	Spring & pin	A313 & A276 Type 316			
126	Stopper plate bolt	Stainless steel			
145	Coned disc spring	Stainless steel			

*1 CF8M or Type 316 is optionally available for balls & stems.

*2 Class 150: Bar type handle used for size 6" & 8".
Class 300: Bar type handle used for size 4" to 8".

*3 Up to size 1 1/4".

*4 A276 Type 304 or equal.

*5 A276 Type 316 or equal.

All part numbers are corresponding with those shown in valve assembly drawings.

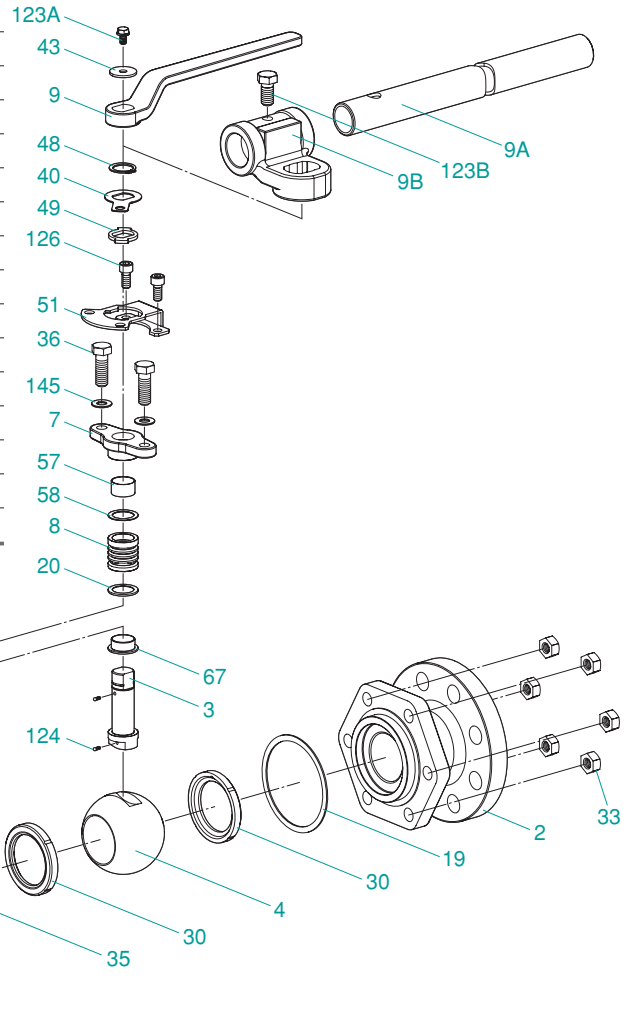

Illustration shows Size 4 design.

PROVIDED BY: PT. SINAR MAS SAKTI
TEL: (62 21) 6008088 - FAX: (62 21) 6293410 - EMAIL: sales@smsakti.com

Construction and Materials

■ Standard material configuration can be applied to sour service.

No.	Parts	Standard	
		150UTB	150UTBM
1	Body	A351 Gr. CF8	A351 Gr. CF8M
2	Body cap	A351 Gr. CF8	A351 Gr. CF8M
3	Stem	A276 Type 304*3	A276 Type 316*4
4	Ball	A276 Type 304*3 or A351 Gr. CF8	A276 Type 316*4 or A351 Gr. CF8M
7	Gland	A351 Gr. CF8	
8	Gland packing	PTFE	
9	Handle*1	Ductile iron	
16A	Nameplate	Aluminum	
16B	Washer	Carbon steel	
19	Gasket	PTFE	
20	Packing washer*2	A276 Type 316*4	
30	Ball seat	HYPATITE® PTFE	
33	Cap nut	A194 Gr. 8	
35	Cap bolt	A193 Gr. B8	
36	Gland bolt	Stainless Steel	
47	Thrust washer	Reinforced PTFE	
48	Snap ring	A276 Type 304*3	
49	Stopper	A276 Type 304*3	
67	Stem bearing	Reinforced PTFE	
123	Handle bolt	6" ~ 10"	Carbon steel
124A	Spring & pin	2 1/2" ~ 10"	A313 & A276 Type 316
124B	Spring	1/2" ~ 2"	A313 Type 316*4

*1 Bar type handles are used for 6" and 8". Worm gear operations are used for 10".

*2 Packing washers are used only for 1" and smaller.

*3 A276 Type 304 or equal.

*4 A276 Type 316 or equal.

All part numbers are corresponding with those shown in valve assembly drawings.

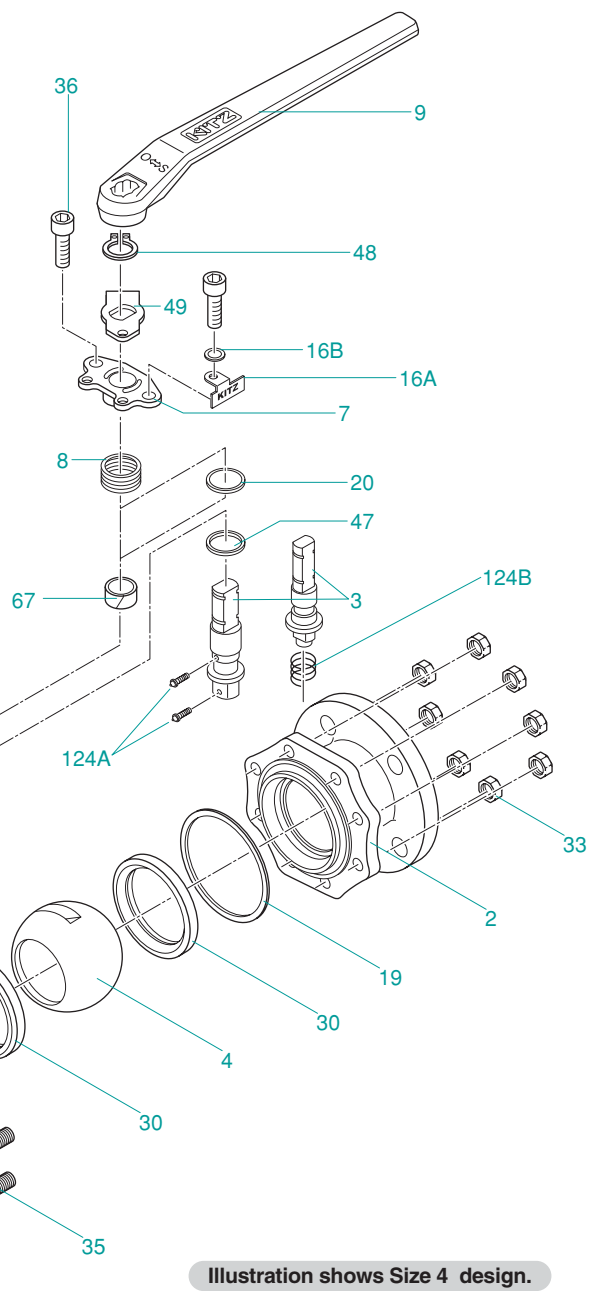

Illustration shows Size 4 design.

Construction and Materials

■ Standard material configuration can be applied to sour service.

No.	Parts	Standard		Super-firesafe	
		150UTA 300UTA	150UTAM 300UTAM	150UTA-FS/UTAM-FS 300UTA-FS/UTAM-FS	
1	Body	A351 Gr. CF8	A351 Gr. CF8M	A351 Gr. CF8/CF8M	
3	Stem	A276 Type 304*2	A276 Type 316*3	A276 Type 304*2/316*3	
4	Ball	A276 Type 304*2	A276 Type 316*3	A276 Type 304*2/316*3	
		A351 Gr. CF8	A351 Gr. CF8M	A351 Gr. CF8/CF8M	
7	Gland	1/2" ~ 1 1/2"	A276 Type 316*3		
		2" ~ 10"	A351 Gr. CF8		
8	Gland packing	PTFE		Flexible graphite	
9	Handle*1	1/2" ~ 1"	Stainless steel		
		1 1/2" ~ "	Ductile iron		
10	Handle nut	1/2" ~ 1 1/2"			Stainless steel
16	Nameplate				Stainless steel
19A	Gasket				PTFE
19B	Secondary gasket	-			Flexible graphite
20	Packing washer	1 1/2" only	A276 Type 316*3		
29	Insert	1/2" ~ 4"	A351 Gr. CF8	A351 Gr. CF8M	A351 Gr. CF8/CF8M
		6" ~ 10"	A182 Gr. F304	A182 Gr. F316	A182 Gr. F304/F316
30	Ball seat				HYPATITE® PTFE
34	Gland nut	1/2" ~ 1 1/2"			Stainless steel
36	Gland bolt	2" ~ 10"			Stainless steel
40	Key lock plate				Stainless steel
43	Coned disc spring	1/2" ~ 1 1/2"			Stainless steel
47	Thrust washer	1/2" ~ 2"			Reinforced PTFE
48	Snap ring	2" ~ 10"			Stainless steel
49	Stopper	1 1/2" ~ 10"			Stainless steel
67	Stem bearing	3" ~ 10"			Reinforced PTFE
123	Handle bolt				Carbon steel
124	Spring & pin				Stainless steel
126	Stopper pin				Stainless steel

*1 Bar type handles are used for 6" and larger.

*2 A276 Type 304 or equal.

*3 A276 Type 316 or equal.

All part numbers are corresponding with those shown in valve assembly drawings.

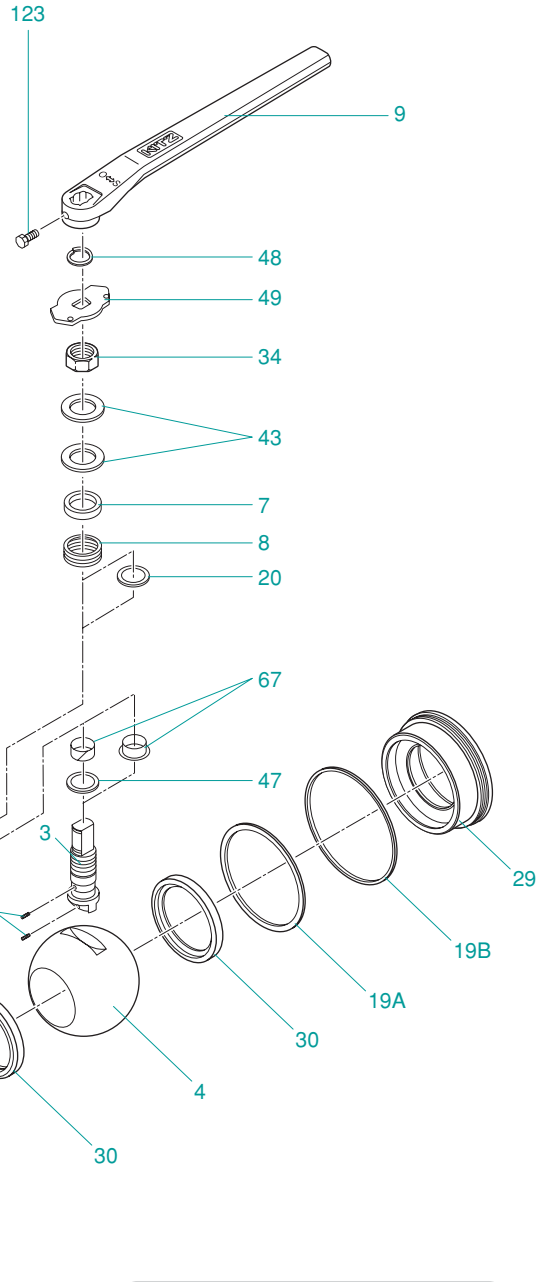

Illustration shows Size 1 1/2" design.

PROVIDED BY: PT. SINAR MAS SAKTI
 TEL: (62 21) 6008088 - FAX: (62 21) 6293410 - EMAIL: sales@smsakti.com

Construction and Materials

No.	Parts	Standard	Super-firesafe
		600SCTB	600SCTBS
1	Body	A105*1	
2	Body cap		
3	Stem	A276 Type 304*2 *4	
4	Ball		
7	Gland	A351 Gr. CF8	
8	Gland packing	PTFE	Flexible graphite
9	Handle	Ductile iron	
16	Nameplate	Stainless steel	
19	Gasket*3	—	Flexible graphite spiral wound
20	Packing washer 1/2"~1"	A276 Type 316*5	
30	Ball seat	Reinforced PTFE with MoS ₂	
33	Cap nut	A194 Gr. 2H	
35	Cap bolt	A193 Gr. B7	
36	Gland bolt	Cr-Mo steel	
45A	O-ring	NBR	—
45B	O-ring	NBR	
47	Thrust washer	Metal-backed PTFE	
48	Snap ring	Carbon steel	
49	Stopper	A276 Type 304*4	
67	Stem bearing	Reinforced PTFE	
124	Spring & pin	A313 & A276 Type 316	
143	Seat spring	A167 Type 304	
150	Seat retainer	A105 Zn plating	
155	Spacer*3	—	PTFE
175	Retainer gland*3	—	A105
176	Retainer packing*3	—	Flexible graphite

■ An optional material configuration is available for sour service.

PROVIDED BY: PT. SINAR MAS SAKTI
 TEL: (62 21) 6008088 - FAX: (62 21) 6293410 - EMAIL: sales@smsakti.com

*1 A350 low-temperature service materials are optionally available.
 *2 Type 316 and other stainless steels are optionally available for ball & stem.
 *3 These parts are used only for super-firesafe provision.
 *4 A276 Type 304 or equal.
 *5 A276 Type 316 or equal.

All part numbers are corresponding with those shown in valve assembly drawings.

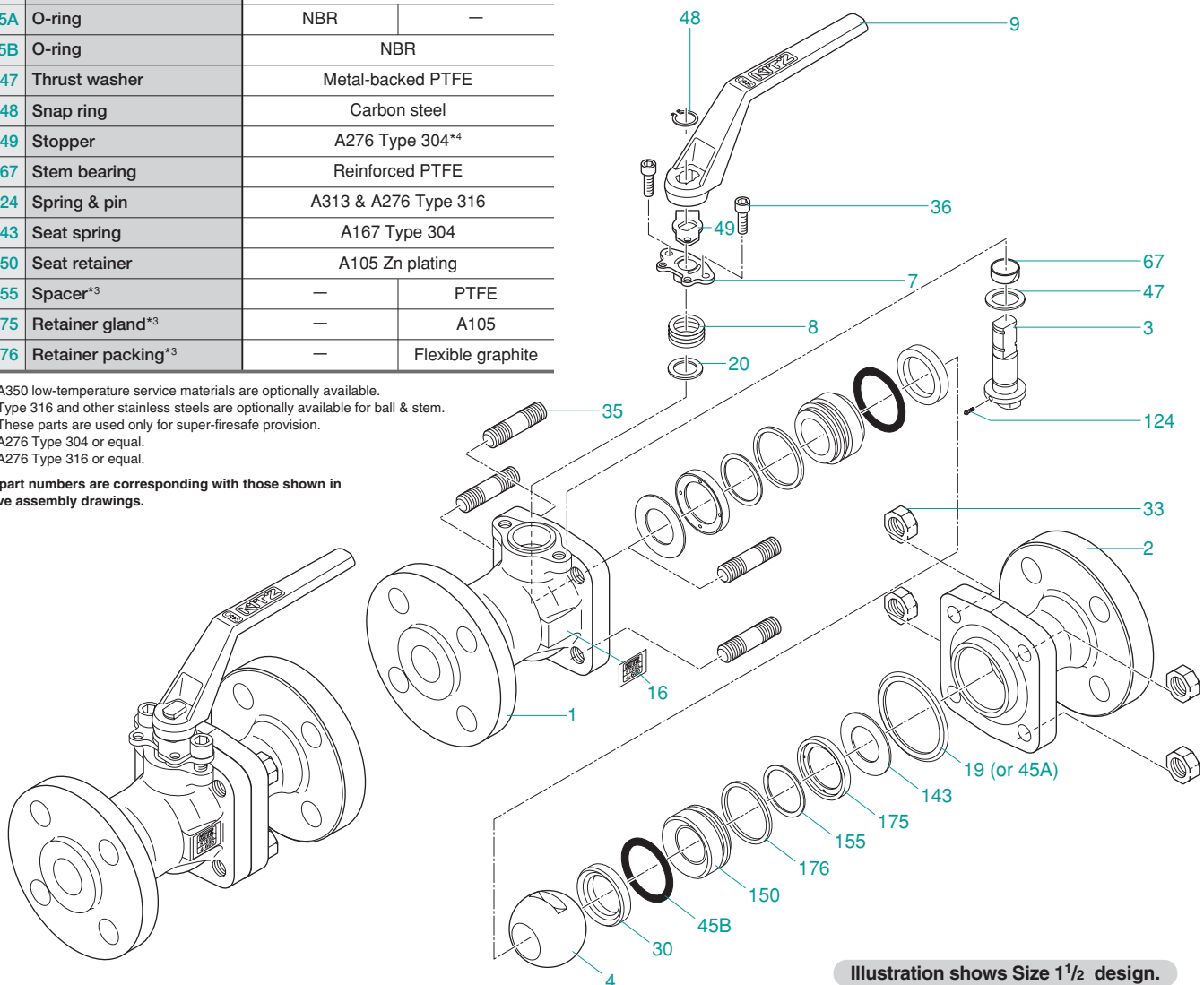

Illustration shows Size 1 1/2 design.

Construction and Materials

■ Standard material configuration can be applied to sour service.

No.	Parts	Standard		Super-firesafe
		600UTB	600UTBM	600UTBS/UTBMS
1	Body	A351 Gr. CF8*2	A351 Gr. CF8M*2	A351 Gr. CF8/CF8M*2
2	Body Cap			
3	Stem	A276 Type 304*2*3	A276 Type 316*2*4	A276 Type 304*3/316*2*4
4	Ball			
7	Gland	A351 Gr. CF8		
8	Gland packing	PTFE		Flexible graphite
9	Handle	Ductile iron		
16	Nameplate	Stainless steel		
19	Gasket*1	—		Flexible graphite spiral wound
20	Packing washer 1/2" ~ 1"	A276 Type 316*4		
30	Ball seat	Reinforced PTFE with MoS ₂		
33	Cap nut	A194 Gr. 8		
35	Cap bolt	A193 Gr. B8		
36	Gland bolt	Stainless Steel		
45A	O-ring	FKM		—
45B	O-ring	FKM		
47	Thrust washer	Metal-backed PTFE		
48	Snap ring	A276 Type 304*3		
49	Stopper	A276 Type 304*3		
67	Stem bearing	Reinforced PTFE		
124	Spring & pin	A313 & A276 Type 316		
143	Seat spring	A167 Type 304	INCONEL X-750	A167 Type 304/ INCONEL X-750
150	Seat retainer	A276 Type 304*3	A276 Type 316*4	A276 Type 304*3/316*4
155	Spacer*1	—		PTFE
175	Retainer gland*1	—		A276 Type 304*3
176	Retainer packing*1	—		Flexible graphite

*1 This parts are used only for super-firesafe provision.

*2 Other stainless steel are optionally available.

*3 A276 Type 304 or equal.

*4 A276 Type 316 or equal.

All part numbers are corresponding with those shown in valve assembly drawings.

Refer to the illustration on Page 45.

Construction and Materials

No.	Parts	Standard	Super-firesafe
		1500SCTB	1500SCTBS
1	Body	A216 Gr. WCB*1	
2	Body cap		
3	Stem	A276 Type 304*2*4	
4	Ball		
7	Gland	A351 Gr. CF8	
8	Gland packing	PTFE	Flexible graphite
9	Handle	Ductile iron	
19	Gasket*3	—	Flexible graphite spiral wound
30	Ball seat	Nylon with MoS ₂	
31	Stem washer	A276 Type 316*5	
33	Cap nut	A194 Gr. 2H	
35	Cap bolt	A193 Gr. B7	
36	Gland bolt	Cr-Mo steel	
45A	O-ring	NBR	—
45B	O-ring	NBR	
47	Thrust washer	Metal-backed PTFE	
48	Snap ring	Carbon steel	
49	Stopper	A276 Type 304*4	
67	Stem bearing	Reinforced PTFE	
85	Plug	A576 Gr. 1025 Zn plating	
124	Spring & pin	A313 & A276 Type 316	
143	Seat spring	A167 Type 304	
146	Back-up ring	PTFE	
150	Seat retainer	A105 Zn plating	
155	Spacer*3	—	PTFE
175	Retainer gland*3	—	A105
176	Retainer packing*3	—	Flexible graphite

■ An optional material configuration is available for sour service.

PROVIDED BY: PT. SINAR MAS SAKTI
 TEL: (62 21) 6008088 - FAX: (62 21) 6293410 - EMAIL: sales@smsakti.com

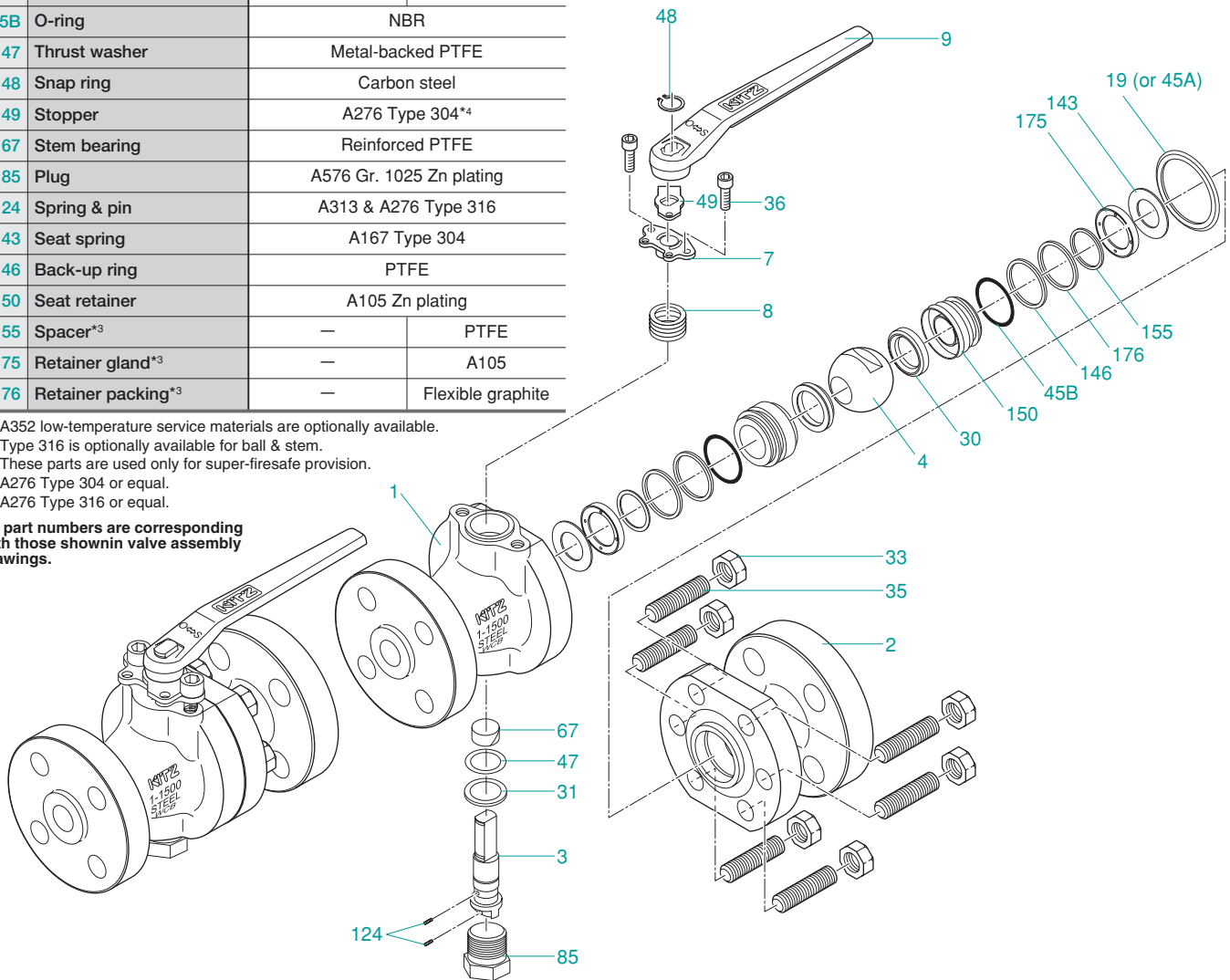

*1 A352 low-temperature service materials are optionally available.
 *2 Type 316 is optionally available for ball & stem.
 *3 These parts are used only for super-firesafe provision.
 *4 A276 Type 304 or equal.
 *5 A276 Type 316 or equal.

All part numbers are corresponding with those shown in valve assembly drawings.

Construction and Materials

■ Standard material configuration can be applied to sour service.

No.	Parts	Standard		Super-firesafe
		1500UTB	1500UTBM	1500UTBS/UTBMS
1	Body	A351 Gr. CF8*2	A351 Gr. CF8M*2	A351 Gr. CF8/CF8M*2
2	Body Cap			
3	Stem	A276 Type 304*2*3	A276 Type 316*2*4	A276 Type 304*3/316*2*4
4	Ball			
7	Gland	A351 Gr. CF8		
8	Gland packing	PTFE		Flexible graphite
9	Handle	Ductile iron		
19	Gasket*1	—		Flexible graphite spiral wound
30	Ball seat	Nylon with MoS ₂		
31	Stem washer	A276 Type 316*4		
33	Cap nut	A194 Gr. 8		
35	Cap bolt	Stainless Steel		
36	Grand bolt	A193 Gr. B8		
45A	O-ring	FPM		—
45B	O-ring	FPM		
47	Thrust washer	Metal-backed PTFE		
48	Snap ring	A276 Type 304*3		
49	Stopper	A276 Type 304*3		
67	Stem bearing	Reinforced PTFE		
85	Plug	A276 Type 316*4		
124	Spring & pin	A313 & A276 Type 316		
143	Seat spring	A167 Type 304	INCONEL X-750	A167 Type 304/ INCONEL X-750
146	Back-up ring	PTFE		
150	Seat retainer	A276 Type 304*3	A276 Type 316*4	PTFE 304*3/316*4
155	Spacer*1	—	—	PTFE
175	Retainer gland*1	—	—	A276 Type 304*3/316*4
176	Retainer packing*1	—	—	Flexible graphite

*1 These parts are used only for super-firesafe provision.

*2 Other stainless steel are optionally available.

*3 A276 Type 304 or equal.

*4 A276 Type 316 or equal.

All part numbers are corresponding with those shown in valve assembly drawings.

Refer to the illustration on Page 47.

Technical Information

PROVIDED BY: PT. SINAR MAS SAKTI
TEL: (62 21) 6008088 - FAX: (62 21) 6293410 - EMAIL: sales@smsakti.com

■ **Technical Features of KITZ HYPATITE® PTFE and SWELLESS® Ball Seats**

■ **General Precautions**

■ **Flow Characteristics**

■ **Steel Pipe Flanges**

Technical Features of KITZ HYPATITE® PTFE and SWELLESS® Ball Seats

KITZ **HYPATITE® PTFE** ball seats are made of denatured PTFE, a molecularly reinforced PTFE copolymer, and specifically engineered for high sealing performance and prolonged service life of valves, in place of conventional glass-filled PTFE seats. The unique performance features are compared with those of conventional glass-filled or virgin PTFE ball seats below. With the introduction of **HYPATITE® PTFE** ball seats, glass-filled PTFE version is not anymore available from KITZ Corporation, while carbon-filled or virgin PTFE seats remain available for special orders.

As a newly developed option, KITZ **SWELLESS®** ball seats principally made of PFA are recommended specifically for monomer service. This epoch-making new seat maximizes resistance to the permeation of monomer into its molecular structure (generally known as a “swelling” problem) which causes seat deformation and seriously affects shut-off function of valves in styrene and butadiene monomer service.

Our **HYPATITE® PTFE** ball seats also outperform conventional PTFE seats with its monomer resistance feature. However, it has been verified both by laboratory and on-site tests that **SWELLESS®** seats perform much better than **HYPATITE® PTFE** seats, as they indeed deserve the name of “SWELLESS”, their registered tradename Besides, PFA resin, the principal material, assures the known features of fluorine resin such as excellent resistance characteristics to high or low temperatures, creep or compression, abrasion and general chemicals.

Table 1 and Figure 1, 2 and 3 here explain these technical features of **HYPATITE® PTFE** and **SWELLESS®** ball seats compared with conventional seat materials.

Table 1. Compared Technical Features of KITZ Ball Seats

Compared features	HYPATITE® PTFE or SWELLESS® seats	PTFE seats	Glass-filled PTFE seats
Heat resistance	Good	—	Good
Sealing performance	Good	Good	Good
Durability (Pitting-proof)	Good	—	Fair
Creep and compress in resistance	Good	—	Fair
Chemical resistance *	Good	Good	—
Abrasion resistance	Good	Good	Good
Firesafe provision	Good	Good	—
Throttling service	Fair	Fair	Fair
Product contamination	None	None	—
Valve operating torque	Low	Low	Low

* Refer to the above body text for monomer service characteristics of **SWELLESS®** seats.

PROVIDED BY: PT. SINAR MAS SAKTI
 TEL: (62 21) 6008088 - FAX: (62 21) 6293410 - EMAIL: sales@smsakti.com

Fig. 1 KITZ Ball Valve Seats Compared Lab Test Results against Gaseous Butadiene Monomer vs. Styrene Monomer

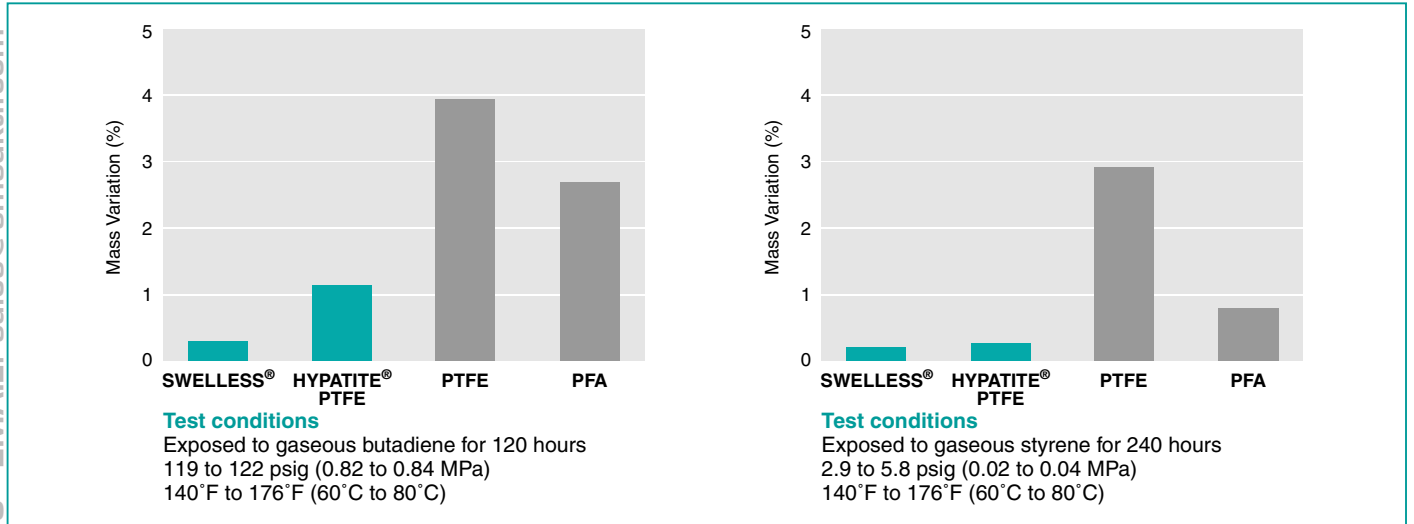

Fig. 2 KITZ Ball Valve Seats Compared Results of Mechanical Load Tests I

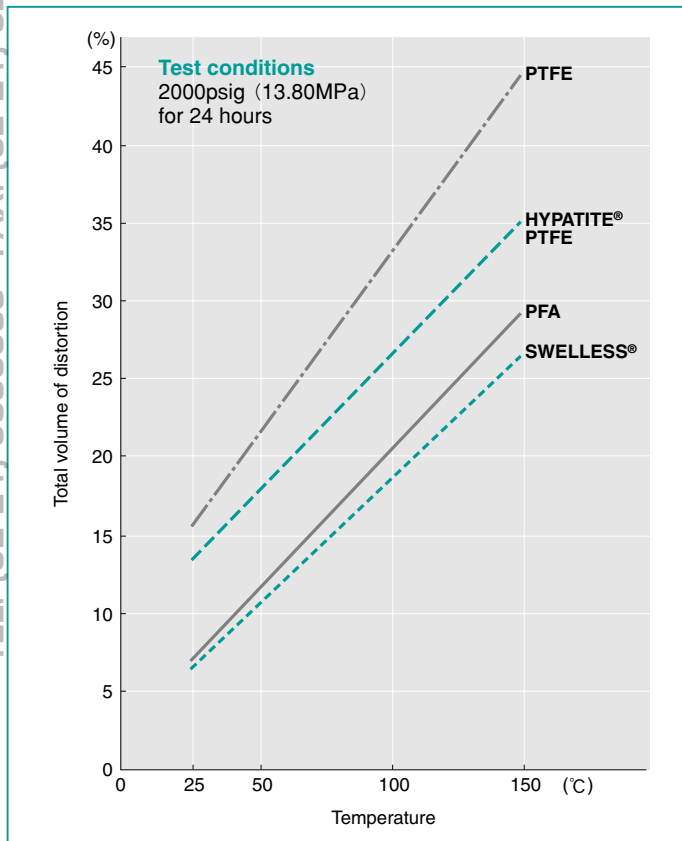
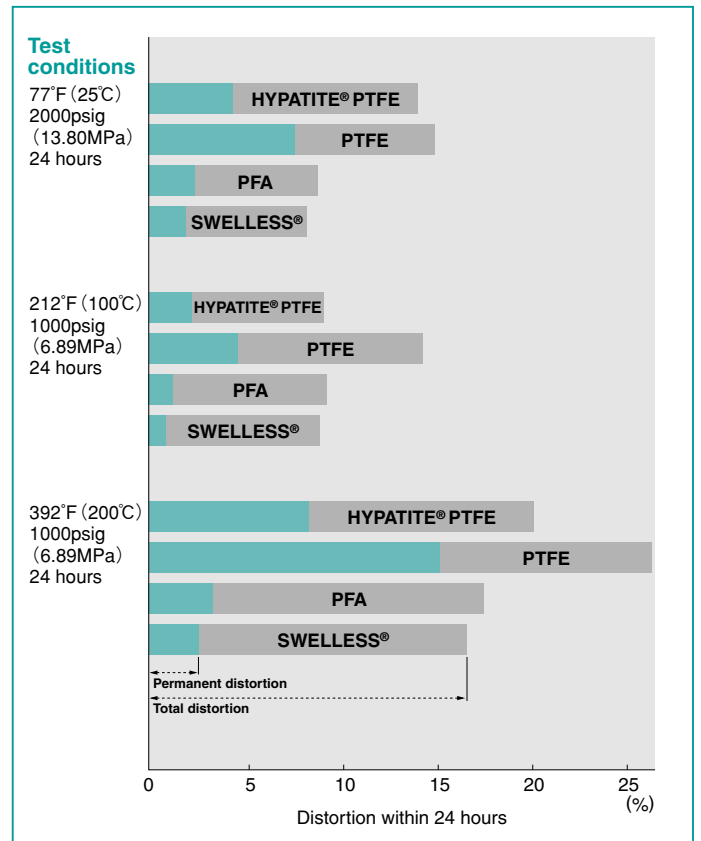

Fig. 3 KITZ Ball Valve Seats Compared Results of Mechanical Load Tests II



These data show results of some of the tests carried out at our laboratory under the specific test conditions introduced here. Variation in the kind of test media, the phase of test media (gaseous or liquid), preparation of test specimen and test conditions such as pressure, temperature and duration, may cause the test results quantitatively different from these data, but general monomer resistance levels of the seats introduced here are comparatively as exhibited in these test data.

PROVIDED BY: PT. SINAR MAS SAKTI
TEL: (62 21) 6008088 - FAX: (62 21) 6293410 - EMAIL: sales@smsakti.com

General Precautions for Trouble-free Operation of Soft-seated Ball Valves

1. Excessive Cavity Pressure

Refer to Page 15. Very important

2. High-Temperature and High-Pressure Service

The pressure-temperature ratings published by manufacturers are usually considered an appropriate guide to the maximum temperature and pressure that such ball valves may withstand. KITZ recommends, however, reference to the valve distributor or manufacturer for an assurance of suitability when ball valves are to be subjected to the following conditions:

- a: **Floating ball valves** are left closed for a long period of time under high temperature or high differential pressure.
- b: **Floating ball valves** are operated frequently for long period of time under high temperature or high differential pressure.
- c: **Floating ball valves** are subjected to frequent change of the line pressure or service temperature.

3. Liquids with High Velocity

When ball valves must be operated frequently on liquids with very high velocity, a check should be made with the valve distributor or manufacturer for appropriate advice to minimize the possibility of seat deformation, especially when they are highly pressurized on high-temperature lines.

4. Valve Selection

Be sure to select a valve with design specifications which meet the pressure and temperature conditions required. Take special care to select the valve to be used for the fluid containing abrasives, since the high molecular materials employed in the seats could suffer degradation.

5. Valve Mounting

Before mounting the valve, the pipe bore should be checked to confirm that no weld spatter, scale or rust particles remain inside. For mounting flanged valves, diagonally located flange bolts should be tightened evenly.

6. Degree of Valve Opening

Ball valves should basically be considered as ON/OFF valves only and care should be taken to ensure that they are fully closed or open. Opening ball valves partially will result in seat erosion and cause seat leakage. Pipelines that require the use of ball valves for throttling service should be designed in consideration of the amount of the seat leakage which may occur in its fully closed position. Note that ball valves should be stored in a fully open position.

7. Valve Actuation

Three types of pneumatic valve actuator (KITZ HAS-Series, KITZ B-Series, F-Series) are available for our factory mounting. Also KITZ "KELMO" electric actuators are available. Electric actuators or pneumatic actuators of any other specified brands are also available for our factory mounting.

In case of user's mounting their own actuators on KITZ ball valves, however, all users are recommended to contact KITZ or its authorized distributors for adequate technical advice, because any improper sizing of actuators may cause serious problems in the field. It must be carefully noted that the actual value of the operating torque of any given valve may vary, depending on the service conditions listed below:

- (1) Fluid
 - a. Kind of fluid
 - b. Line pressure
 - c. Line temperature
 - d. Fluid volume
- (2) Ambient temperature
- (3) Opening/closing degree
- (4) Type of actuator
- (5) Frequency and pattern of change of line pressure
- (6) Frequency and pattern of change of line and ambient temperatures

8. Valve Disassembly

The line fluid should be completely removed from the internal of the valves before they are dismantled from the pipeline for maintenance.

Even after the line fluid has been discharged through the pipeline, some fluid is always trapped inside the body and body cavity (the room surrounded by the body, ball and two seats).

Be sure to completely discharge the pressure trapped in the body cavity, before valve disassembly.

Inspection and Warranty

Each KITZ ball valve is subjected to 100% in-house inspection designated by API 598 or BS 6755 Part 1. This includes hydrostatic shall tests and pneumatic low-pressure seat test. Manufacturer's material certificates and test reports are available upon request. Each KITZ ball valve is guaranteed for 12 months after placement in service, but not exceeding 18 months after shipment from KITZ factories.

Flow Characteristics

One of the best advantages of ball valves is that every flow per any given bore size is larger than other types of valves. Fluid is much less disturbed by eddy currents or pulsation. To obtain the figure of flow per valve opening, simply multiply the flow rate (%) given here by the corresponding value given in the table of Pressure Loss vs. Flow Rate.

Valve opening vs. flow rate

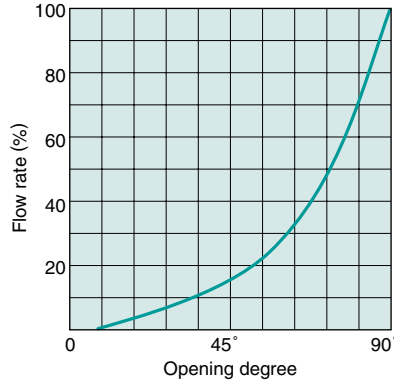

Pressure Loss vs. Flow Rate

Full port valves

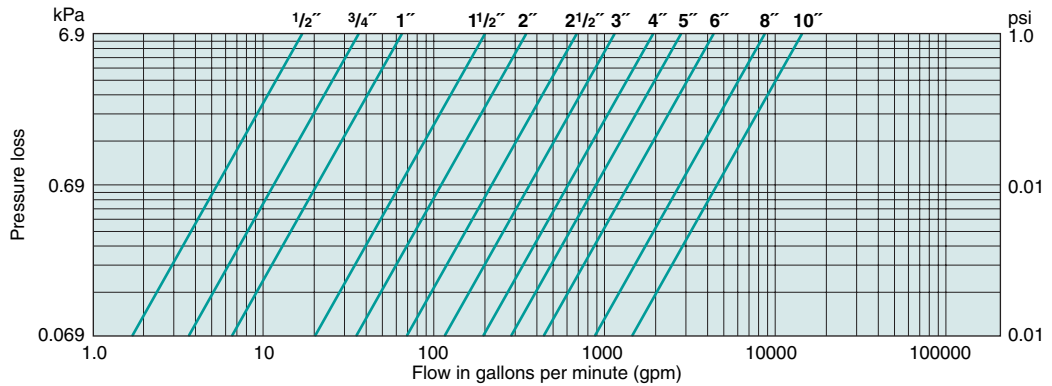

Reduced port valves

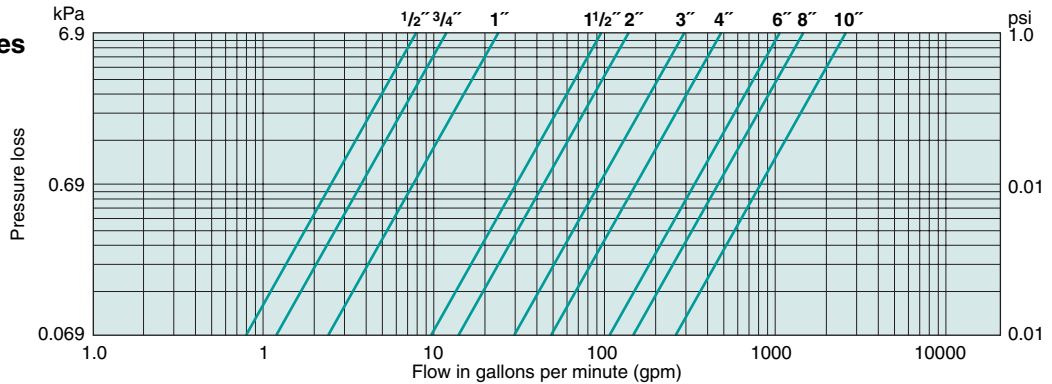

Schedule 40 steel pipe (10m)

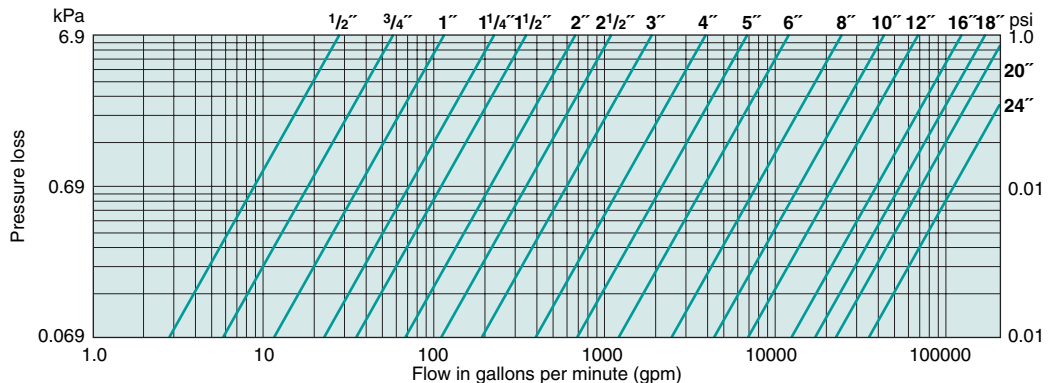

PROVIDED BY: PT. SINAR MAS SAKTI
 TEL: (62 21) 6008088 - FAX: (62 21) 6293410 - EMAIL: sales@smsakti.com

Steel Pipe Flanges

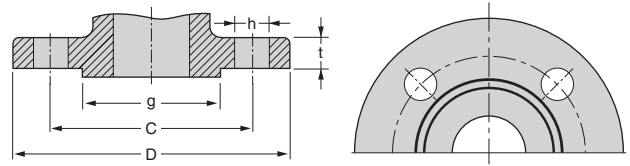

ASME B16.5-1996 Class 150 RF, Class 300 RF

Class 150 steel pipe flange dimensions

Nominal Size		D		C		g		t		h (Bolt hole)		Bolt	
inch	mm	in.	mm	in.	mm	in.	mm	in.	mm	in.	mm	Number	Diam.
1/2	15	3.50	89	2.38	60.5	1.38	35	0.44	11.2	0.62	16	4	1/2
3/4	20	3.88	98	2.75	70.0	1.69	43	0.50(0.44)	12.7(11.2)	0.62	16	4	1/2
1	25	4.25	108	3.12	79.5	2.00	51	0.56(0.44)	14.3(11.2)	0.62	16	4	1/2
1 1/4	32	4.62	117	3.50	89.0	2.50	64	0.62(0.50)	15.9(12.7)	0.62	16	4	1/2
1 1/2	40	5.00	127	3.88	98.5	2.88	73	0.69(0.56)	17.5(14.3)	0.62	16	4	1/2
2	50	6.00	152	4.75	120.5	3.62	92	0.75(0.62)	19.1(15.9)	0.75	19	4	5/8
2 1/2	65	7.00	178	5.50	139.5	4.12	105	0.88(0.69)	22.3(17.5)	0.75	19	4	5/8
3	80	7.50	190	6.00	152.5	5.00	127	0.94(0.75)	23.9(19.1)	0.75	19	4	5/8
4	100	9.00	229	7.50	190.5	6.19	157	0.94	23.9	0.75	19	8	5/8
5	125	10.00	254	8.50	216.5	7.31	186	0.94	23.9	0.88	22	8	3/4
6	150	11.00	279	9.50	241.5	8.50	216	1.00	25.4	0.88	22	8	3/4
8	200	13.50	343	11.75	298.5	10.62	270	1.12	28.6	0.88	22	8	3/4
10	250	16.00	406	14.25	362.0	12.75	324	1.19	30.2	1.00	25	12	7/8
12	300	19.00	483	17.00	432.0	15.00	381	1.25	31.8	1.00	25	12	7/8
14	350	21.00	533	18.75	476.5	16.25	413	1.38	35.0	1.12	29	12	1
16	400	23.50	597	21.25	539.5	18.50	470	1.44	36.6	1.12	29	16	1
18	450	25.00	635	22.75	578.0	21.00	533	1.56	39.7	1.25	32	16	1 1/8
20	500	27.50	698	25.00	635.0	23.00	584	1.69	42.9	1.25	32	20	1 1/8
24	600	32.00	813	29.50	749.5	27.25	692	1.88	47.7	1.38	35	20	1 1/4

Height of raised face is 0.06 inch (1.6 mm) each. Dimensions in () are for valve flanges.

Class 300 steel pipe flange dimensions

Nominal Size		D		C		g		t		h (Bolt hole)		Bolt	
inch	mm	in.	mm	in.	mm	in.	mm	in.	mm	in.	mm	Number	Diam.
1/2	15	3.75	95	2.62	66.5	1.38	35	0.56	14.3	0.62	16	4	1/2
3/4	20	4.62	117	3.25	82.5	1.69	43	0.62	15.9	0.75	19	4	5/8
1	25	4.88	124	3.50	89.0	2.00	51	0.69	17.5	0.75	19	4	5/8
1 1/4	32	5.25	133	3.88	98.5	2.50	64	0.75	19.1	0.75	19	4	5/8
1 1/2	40	6.12	156	4.50	114.5	2.88	73	0.81	20.7	0.88	22	4	3/4
2	50	6.50	165	5.00	127.0	3.62	92	0.88	22.3	0.75	19	8	5/8
2 1/2	65	7.50	190	5.88	149.0	4.12	105	1.00	25.4	0.88	22	8	3/4
3	80	8.25	210	6.62	168.0	5.00	127	1.12	28.6	0.88	22	8	3/4
4	100	10.00	254	7.88	200.0	6.19	157	1.25	31.8	0.88	22	8	3/4
5	125	11.00	279	9.25	235.0	7.31	186	1.38	35.0	0.88	22	8	3/4
6	150	12.50	318	10.62	270.0	8.50	216	1.44	36.6	0.88	22	12	3/4
8	200	15.00	381	13.00	330.0	10.62	270	1.62	41.3	1.00	25	12	7/8
10	250	17.50	444	15.25	387.5	12.75	324	1.88	47.7	1.12	29	16	1
12	300	20.50	521	17.75	451.0	15.00	381	2.00	50.8	1.25	32	16	1 1/8
14	350	23.00	584	20.25	514.5	16.25	413	2.12	54.0	1.25	32	20	1 1/8
16	400	25.50	648	22.50	571.5	18.50	470	2.25	57.2	1.38	35	20	1 1/4
18	450	28.00	711	24.75	628.5	21.00	533	2.38	60.4	1.38	35	24	1 1/4
20	500	30.50	775	27.00	686.0	23.00	584	2.50	63.5	1.38	35	24	1 1/4
24	600	36.00	914	32.00	813.0	27.25	692	2.75	69.9	1.62	41	24	1 1/2

Height of raised face is 0.06 inch (1.6 mm) each.

PROVIDED BY: PT. SINAR MAS SAKTI
TEL: (62 21) 6008088 - FAX: (62 21) 6293410 - EMAIL: sales@smsakti.com

Steel Pipe Flanges

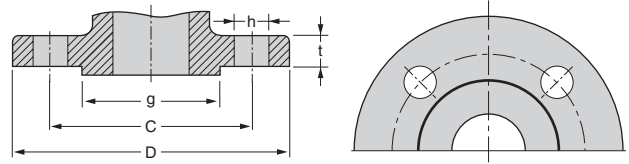

Class 600 RF

Class 600 steel pipe flange dimensions

Nominal Size		D		C		g		t		h (Bolt hole)		Bolt	
inch	mm	in.	mm	in.	mm	in.	mm	in.	mm	in.	mm	Number	Diam.
1/2	15	3.75	95	2.62	66.5	1.38	35	0.56	14.3	0.62	16	4	1/2
3/4	20	4.62	117	3.25	82.5	1.69	43	0.62	15.9	0.75	19	4	5/8
1	25	4.88	124	3.50	89.0	2.00	51	0.69	17.5	0.75	19	4	5/8
1 1/4	32	5.25	133	3.88	98.5	2.50	64	0.81	20.7	0.75	19	4	5/8
1 1/2	40	6.12	156	4.50	114.5	2.88	73	0.88	22.3	0.88	22	4	3/4
2	50	6.50	165	5.00	127.0	3.62	92	1.00	25.4	0.75	19	8	5/8
2 1/2	65	7.50	190	5.88	149.0	4.12	105	1.12	28.6	0.88	22	8	3/4
3	80	8.25	210	6.62	168.0	5.00	127	1.25	31.8	0.88	22	8	3/4
4	100	10.75	273	8.50	216.0	6.19	157	1.50	38.1	1.00	25	8	7/8
5	125	13.00	330	10.50	266.5	7.31	186	1.75	44.5	1.12	29	8	1
6	150	14.00	356	11.50	292.0	8.50	216	1.88	47.7	1.12	29	12	1
8	200	16.50	419	13.75	349.0	10.62	270	2.19	55.6	1.25	32	12	1 1/8
10	250	20.00	508	17.00	432.0	12.75	324	2.50	63.5	1.38	35	16	1 1/4
12	300	22.00	559	19.25	489.0	15.00	381	2.62	66.7	1.38	35	20	1 1/4
14	350	23.75	603	20.75	527.0	16.25	413	2.75	69.9	1.50	38	20	1 3/8
16	400	27.00	686	23.75	603.0	18.50	470	3.00	76.2	1.62	41	20	1 1/2
18	450	29.25	743	25.75	654.0	21.00	533	3.25	82.6	1.75	45	20	1 5/8
20	500	32.00	813	28.50	724.0	23.00	584	3.50	88.9	1.75	45	24	1 5/8
24	600	37.00	940	33.00	838.0	27.25	692	4.00	101.6	2.00	51	24	1 7/8

Height of raised face is 0.25 inch (6.4 mm) each.

Steel Pipe Flanges

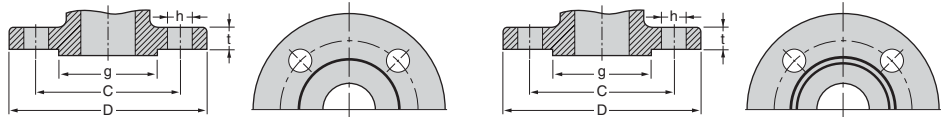

Class 600 to 1500

Class 150, 300

Class 1500 RF

Class 1500 steel pipe flange dimensions

Nominal Size		D		C		g		t		h (Bolt hole)		Bolt	
inch	mm	in.	mm	in.	mm	in.	mm	in.	mm	in.	mm	Number	Diam.
1/2	15	4.75	121	3.25	82.5	1.38	35	0.88	22.4	0.88	22	4	3/4
3/4	20	5.12	130	3.50	89.0	1.69	43	1.00	25.4	0.88	22	4	3/4
1	25	5.88	149	4.00	101.5	2.00	51	1.12	28.5	1.00	25	4	7/8
1 1/4	32	6.25	159	4.38	111.0	2.50	64	1.12	28.5	1.00	25	4	7/8
1 1/2	40	7.00	178	4.88	124.0	2.88	73	1.25	31.8	1.12	29	4	1
2	50	8.50	216	6.50	165.0	3.62	92	1.50	38.1	1.00	25	8	7/8
2 1/2	65	9.62	244	7.50	190.5	4.12	105	1.62	41.2	1.12	29	8	1
3	80	10.50	267	8.00	203.0	5.00	127	1.88	47.8	1.25	32	8	1 1/8
4	100	12.25	311	9.50	241.5	6.19	157	2.12	53.9	1.38	35	8	1 1/4
5	125	14.75	375	11.50	292.0	7.31	186	2.88	73.2	1.62	41	8	1 1/2
6	150	15.50	394	12.50	317.5	8.50	216	3.25	82.6	1.50	38	12	1 3/8
8	200	19.00	483	15.50	393.5	10.62	270	3.62	92.0	1.75	45	12	1 5/8
10	250	23.00	584	19.00	482.5	12.75	324	4.25	108.0	2.00	51	12	1 7/8
12	300	26.50	673	22.50	571.5	15.00	381	4.88	124.0	2.12	54	16	2
14	350	29.50	749	25.00	635.0	16.25	413	5.25	133.4	2.38	60	16	2 1/4
16	400	32.50	826	27.75	705.0	18.50	470	5.75	146.1	2.62	67	16	2 1/2
18	450	36.00	914	30.50	774.5	21.00	533	6.38	162.1	2.88	73	16	2 3/4
20	500	38.75	984	32.75	832.0	23.00	584	7.00	177.8	3.12	79	16	3
24	600	46.00	1168	39.00	990.5	27.25	692	8.00	203.2	3.62	92	16	3 1/2

Height of raised face is 0.25 inch (6.4 mm) each.

ASME B16.47-1996 (Series A)

Class 150 steel pipe flange dimensions

Nominal Size		D		C		g		t		h (Bolt hole)		Bolt	
inch	mm	in.	mm	in.	mm	in.	mm	in.	mm	in.	mm	Number	Diam.
26	650	34.25	870	31.75	806.5	29.50	749	2.69	68.4	1.38	35	24	1 1/4
28	700	36.50	927	34.00	863.5	31.50	800	2.81	71.4	1.38	35	28	1 1/4
30	750	38.75	984	36.00	914.5	33.75	857	2.94	74.7	1.38	35	28	1 1/4
32	800	41.75	1060	38.50	978.0	36.00	914	3.18	80.8	1.62	41	28	1 1/2
34	850	43.75	1111	40.50	1029.0	38.00	965	3.25	82.6	1.62	41	32	1 1/2
36	900	46.00	1168	42.75	1086.0	40.25	1022	3.56	90.5	1.62	41	32	1 1/2

Height of raised face is 0.06 inch (1.6 mm) each.

Class 300 steel pipe flange dimensions

Nominal Size		D		C		g		t		h (Bolt hole)		Bolt	
inch	mm	in.	mm	in.	mm	in.	mm	in.	mm	in.	mm	Number	Diam.
26	650	38.25	972	34.50	876.5	29.50	749	3.12	79.3	1.75	45	28	1 5/8
28	700	40.75	1035	37.00	940.0	31.50	800	3.38	85.9	1.75	45	28	1 5/8
30	750	43.00	1092	39.25	997.0	33.75	857	3.62	92.0	1.88	48	28	1 3/4
32	800	45.25	1149	41.50	1054.0	36.00	914	3.88	98.6	2.00	51	28	1 7/8
34	850	47.50	1207	43.50	1105.0	38.00	965	4.00	101.6	2.00	51	28	1 7/8
36	900	50.00	1270	46.00	1168.5	40.25	1022	4.12	104.7	2.12	54	32	2

Height of raised face is 0.06 inch (1.6 mm) each.

Class 600 steel pipe flange dimensions

Nominal Size		D		C		g		t		h (Bolt hole)		Bolt	
inch	mm	in.	mm	in.	mm	in.	mm	in.	mm	in.	mm	Number	Diam.
26	650	40.00	1016	36.00	914.5	29.50	749	4.25	108.0	2.00	51	28	1 7/8
28	700	42.25	1073	38.00	965.0	31.50	800	4.38	111.3	2.12	54	28	2
30	750	44.50	1130	40.25	1022.5	33.75	857	4.50	114.3	2.12	54	28	2

Height of raised face is 0.25 inch (6.4 mm) each.

PROVIDED BY: PT. SINAR MAS SAKTI
 TEL: (62 21) 6008088 - FAX: (62 21) 6293410 - EMAIL: sales@smsakti.com

NOTE

If any products designated as strategic material in the Foreign Exchange and Foreign Trade Law, Cabinet Order Concerning Control of Export Trade, Cabinet Order Concerning Control of Foreign Exchange and other related laws and ordinances ("Foreign Exchange Laws") are exported to any foreign country or countries, an export license issued by the Japanese Government will be required under the Foreign Exchange Laws.

Further, there may be cases where an export license issued by the government of the United States or other country will be required under the applicable export-related laws and ordinances in such relevant countries.

The contract shall become effective subject to that a relevant export license is obtained from the Japanese Government.

CAUTION

Pressure-temperature ratings and other performance data published in this catalog have been developed from our design calculation, in-house testing, field reports provided by our customers and/or published official standards or specifications. They are good only to cover typical applications as a general guideline to users of KITZ products introduced in this catalog.

For any specific application, users are kindly requested to contact KITZ Corporation for technical advice, or to carry out their own study and evaluation for proving suitability of these products to such an application. Failure to follow this request could result in property damage and/or personal injury, for which we shall not be liable.

While this catalog has been compiled with the utmost care, we assume no responsibility for errors, impropriety or inadequacy. Any information provided in this catalog is subject to from-time-to-time change without notice for error rectification, product discontinuation, design modification, new product introduction or any other cause that KITZ Corporation considers necessary. This edition cancels all previous issues.

Read instruction manual carefully before use.

NOTICE

If any products designated as strategic material in the Foreign Exchange and Foreign Trade Law, Cabinet Order Concerning Control of Export Trade, Cabinet order Concerning Control of Foreign Exchange and other related laws and ordinances ("Foreign Exchange Laws") are exported to any foreign country or countries, an export license issued by the Japanese Government will be required under the Foreign Exchange Laws.

Further, there may be cases where an export license issued by the government of the United States or other country will be required under the applicable export-related laws and ordinances in such relevant countries.

The contract shall become effective subject to that a relevant export license is obtained from the Japanese Government.

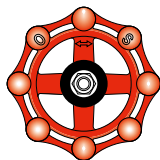

*A chrysanthemum-handle is a symbol of KITZ,
the brand of valve reliability*

ISO 9001 certified since 1989

KITZ
KITZ CORPORATION

1-10-1, Nakase, Mihama-ku, Chiba 261-8577, Japan
International Sales Dept. Phone : 81-43-299-1730, 1732 and 1733
Fax : 81-43-299-0121

— Distributed by —